

Chef[®]
TESTED ✓

by **Montgomery Ward**[®]

Chef[®]
TESTED ✓

by **Montgomery Ward**[®]

Start your
day off right
with fresh-
brewed coffee,
ready and
waiting!

12-Cup Digital Coffeemaker



Instruction Manual

MODEL: FCZD15R_CT, FCZD127S_CT
120V~, 60Hz, 900W

Montgomery Ward Customer Service
3650 Milwaukee Street, Madison, WI 53714
8:00 am to Midnight, Monday through Friday

Wards.com 1-888-557-3848

Wards.com 1-888-557-3848



Chef[®] TESTED ✓

by **Montgomery Ward[®]**

Thank you for purchasing your Chef Tested[®] 12-Cup Digital Coffeemaker by Montgomery Ward[®]. Put through the paces by the experts, we guarantee that it will perform to the highest standard, time after time, with all the convenience, easy clean-up and durability you rely on from Wards.

Break the expensive boutique coffee shop habit with a pot of fresh-brewed coffee ready and waiting for you every morning! Your new coffeemaker is completely programmable, easy to use and includes both mesh and regular filter baskets; the pause-n-pour feature lets you sneak a cup when you can't wait and the sleek design of the machine adds panache to your counter.

Table of Contents

Important Safeguards	3-4
Polarized Plug.....	5
Parts & Features.....	6
Before Using for the First Time	7
How to Use	7-10
Hints for Great-Tasting Coffee	11
Care & Maintenance.....	12-13
Warranty & Return Information.....	14-15

PLEASE SAVE THESE INSTRUCTIONS

THIS APPLIANCE IS FOR HOUSEHOLD USE ONLY

© 2014 Montgomery Ward, Inc. All rights reserved.

Important Safeguards

PLEASE READ THESE INSTRUCTIONS BEFORE USE

Basic safety precautions should always be followed when using your Coffeemaker, especially when children are present.

WARNING: TO AVOID THE RISK OF ELECTRICAL SHOCK, ALWAYS MAKE SURE THE PRODUCT IS UNPLUGGED FROM THE ELECTRICAL OUTLET BEFORE ASSEMBLING, DISASSEMBLING, RELOCATING, SERVICING OR CLEANING

1. Keep the appliance out of the reach of children and pets. This appliance is not intended for use by children. Extra caution and close supervision are necessary when using any appliance near children.
2. Unplug the coffeemaker from the electrical outlet when not in use.
3. Do NOT touch hot surfaces; always use handles and/or knobs to avoid burns or personal injury. Do NOT move the appliance while it is brewing or when the Carafe contains hot liquids.
4. Do NOT immerse the power cord, plug or coffeemaker in water or other liquids.
5. Do NOT use accessory attachments not recommended by the appliance manufacturer.
6. Do NOT place on or near a hot gas or electric burner, or in a heated oven.
7. To disconnect from an electrical outlet, turn the coffeemaker off by pressing the On/Auto/Off button twice, then pull directly on the plug; do NOT pull on the Power Cord.
8. Do NOT lift the lid during brewing cycles, as scalding may occur.
9. Do NOT use the carafe on a range top, as it is designed for use with this appliance only.
10. Do NOT plug/unplug the appliance into/from the electrical outlet with a wet hand.
11. Do NOT remove the bottom cover of the appliance.
12. Do NOT put any stress on the power cord where it connects to the product, as the power cord could fray and break.

Important Safeguards (cont'd)

13. Do NOT operate this appliance if it has a damaged or cut power cord or plug, if wires are exposed, if it malfunctions, if it is dropped or damaged, or if it is dropped in water. Call our toll-free Customer Service for information on returns or replacement.
14. This product has no user-serviceable parts. Do NOT attempt to examine or repair this product yourself. Call our Toll-free Customer Service for information on returns or exchanges.
15. Do NOT allow the power cord to touch hot surfaces.
16. This product is intended for indoor use only. Do NOT use outdoors or for any other purpose.
17. Do NOT set the hot carafe on a wet or cold surface, as the temperature difference between the hot carafe and the cooler surface may cause the carafe to break.
18. Do NOT use a cracked carafe or one having a loose or weakened handle.
19. Do NOT use cleansers, steel wool pads or other abrasive materials to clean the Carafe. When hand washing the carafe, remove any rings/jewelry from your fingers to prevent scratching the carafe glass; scratches in the carafe may result in premature failure.
20. Always operate the product on a flat, stable and heat-resistant surface.

Polarized Plug

This appliance has a polarized plug (one blade is wider than the other). As a safety feature to reduce the risk of electrical shock, this plug is intended to fit a polarized outlet only one way. If the plug does not fit fully in the outlet, reverse the plug. If it still does not fit, contact a qualified electrician. Do not attempt to modify the plug in any way.

SHORT CORD INSTRUCTIONS

1. A short power supply cord is provided to reduce the risk resulting from becoming entangled in or tripping over a longer cord.
2. Longer detachable power-supply cords or extension cords are available and may be used if care is exercised in their use.
3. If a long detachable power cord or extension cord is used:
 - The marked electrical rating of the detachable power supply cord or extension cord should be at least as great as the electrical rating of the appliance.
 - If the appliance is of the grounded type, the extension cord should be the same type 3-wire.
 - The longer cord should be arranged so that it will not drape over the counter top or table top where it can be pulled on by children or tripped over.

PLASTICIZER WARNING

CAUTION: To prevent Plasticizers from migrating from the finish of the counter top or table top or other furniture, place NON-PLASTIC coaster or placemats between the appliance and the finish of the counter top or table top. **Failure to do so may cause the finish to darken. Permanent blemishes may occur or stains can appear.**

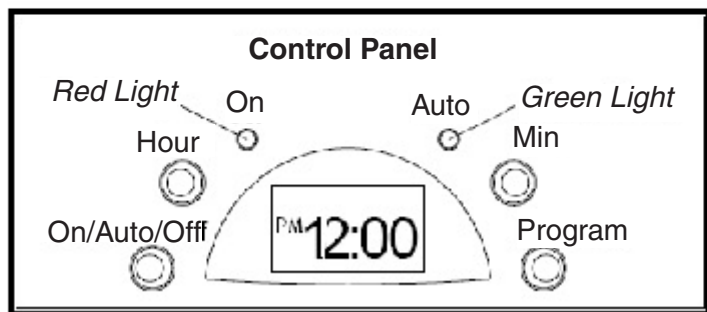
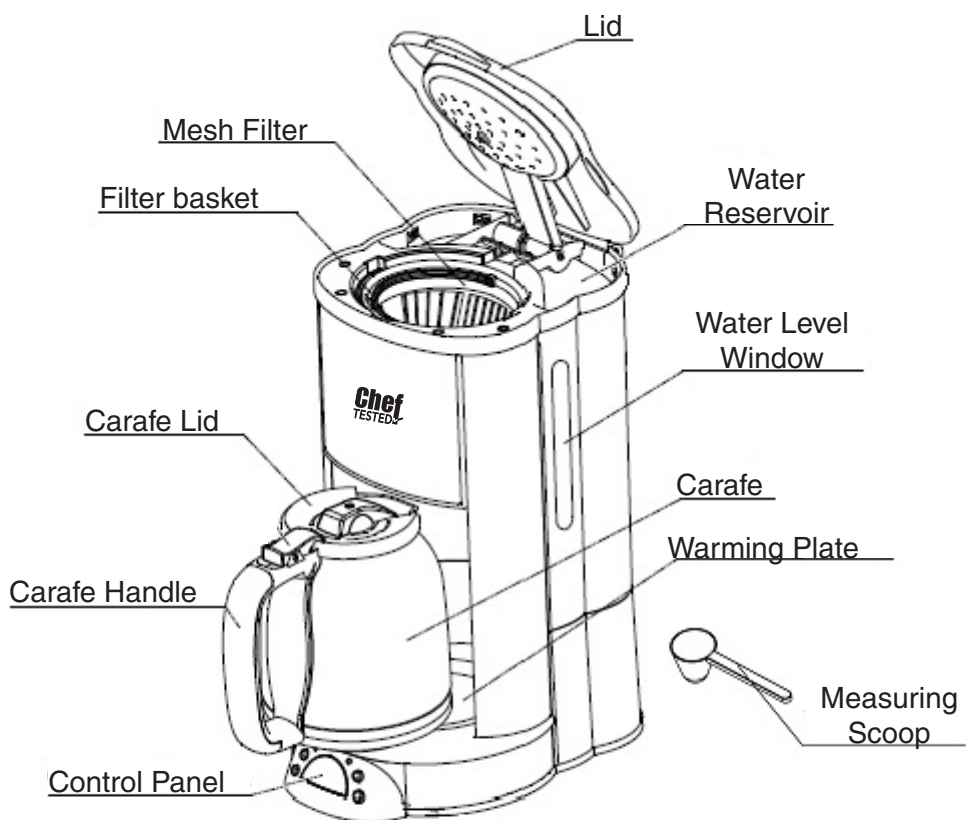

Figure 1

1. Make sure the carafe lid is securely attached to the carafe.
2. Brew two carafes of fresh water (see the "To Brew Coffee" section) without adding any coffee grounds.

NOTE: After brewing the first carafe of water, press the On/Auto/Off button twice to turn the product off, wait ten minutes, then brew a second carafe of water.

3. Thoroughly clean the carafe, carafe lid, filter basket and mesh filter in hot, soapy water; rinse thoroughly and let dry.

How to Use

To Set the Clock:

NOTE: The time will need to be reset if electrical power is interrupted.

1. Plug the power cord into a standard 120-volt AC electrical outlet.
2. Press the Program Button until "CLOCK" appears in the upper right of the display (see Figure 2). Press and release the "HOUR" and "MIN" Buttons until the correct hour and minutes appear in the display.



Figure 2

NOTE: The "AM" or "PM" designation will appear to the left of the time (as in Figure 2).

3. Press the Program Button twice to set the time. If no buttons are pressed, after approximately 15 seconds, "CLOCK" will disappear from the display and the clock will be set.

To Brew Coffee:

Suggested Coffee Measurement

To Brew:	Use this much coffee grounds:
12 cups	9 Tbsp.
10 cups	7.5 Tbsp.
8 cups	6.5 Tbsp.
6 cups	4.5 Tbsp.
4 cups	3 Tbsp.
2 cups	1.5 Tbsp.

1 scoop= 1 Tbsp.= 5g

1 cup= 5 fl. oz. brewed coffee

Use more or less coffee grounds to suit your taste

Step-by-Step Instructions:

1. Lift the lid and fill the water reservoir (located behind the filter basket) with the desired number of cups* of coffee as indicated by the markings on the water level window. See Figure 1 below.

NOTICE: To avoid potential overheating of the coffeemaker, never brew less than two cups* of coffee.

2. Ensure the filter basket is properly seated and place the reusable mesh filter or a #4 cone filter into the filter basket.

3. Add the appropriate amount of drip or regular ground coffee to the filter basket as listed in the "Suggested Coffee Measurement" table above. For stronger or more mild coffee, increase or decrease the amount of coffee to suit your taste.

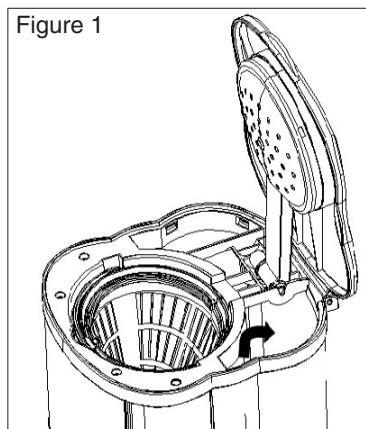

Figure 1

4. Gently tap the filter basket to distribute the coffee evenly.
5. Close the lid and place the carafe onto the warming plate.
6. For immediate brewing, press the On/Auto/Off button once; the On LED Indicator will illuminate red. For a delayed start time, reference the "For Timer Brewing" section.

NOTE: Since coffee grounds absorb some water during brewing, the amount of brewed coffee will be slightly less than the amount of water poured into the Coffeemaker. For safety purposes, always keep the carafe lid on the carafe when pouring coffee. The carafe lid will also assist in keeping the coffee at serving temperature.

7. To interrupt the brewing cycle in order to pour coffee, simply remove the carafe from the warming plate. This will engage the "Pause and Pour" feature, causing the unit to temporarily stop the flow of coffee.

NOTICE: Hot water will continue to build up inside the filter basket. Be sure to **return the Carafe to the Warming Plate within 30 seconds** to prevent overflow.

8. To keep the coffee at a hot serving temperature, return the carafe to the warming plate after pouring. The warming plate cycles to keep the carafe contents hot for two hours.

9. When the carafe is empty, either prepare the unit for brewing an additional pot of coffee (see the "Brewing a Second Pot of Coffee" section) or turn the coffeemaker off (press the On/Auto/Off button twice).

NOTE: If the product is not unplugged or the On/Auto/Off button is not pressed twice to turn off the coffeemaker, it will turn off by itself in approximately two hours.

*NOTE: This unit yields approximately five fluid ounces per cup.

Brewing a Second Pot of Coffee:

1. To brew a second pot of coffee within a short period, press the On/Auto/Off button twice to turn the unit off and wait 10 minutes for the heating element to cool.
2. Remove and dispose of the used coffee grounds. Rinse the carafe and reusable mesh filter with water and repeat the brewing instructions detailed on the previous page.

WARNING: If the coffeemaker does not cool completely before reuse, water placed in the water reservoir may overheat, causing steam to be released. This poses a risk of burns and/or other serious personal injury.

For Timer Brewing:

NOTE: It will be necessary to reset the brewing start time on the coffeemaker if electrical power is interrupted.

1. Ensure the current clock time is set correctly.
2. Press the Program Button twice and "TIMER" will appear in the LED Display (see Figure 3).



Figure 3

3. Press and release the "HOUR" and/or "MIN" Buttons until the desired brewing start time appears in the display.

NOTE: "AM" or "PM" will appear to the left of the time display (as in Figure 3).

4. To activate the brewing timer, press the On/Auto/Off Button again.

IMPORTANT NOTE: Reference the "To Brew Coffee" section to prepare the coffee-maker properly for brewing.

NOTICE: To avoid overheating the coffeemaker, never leave the brewing timer on without water and coffee in the unit.

Hints for Great-Tasting Coffee:

- A clean coffeemaker is essential for making great-tasting coffee. Regularly clean the coffeemaker as detailed in the "Care and Maintenance" section.
- Always use fresh, cold water in the coffeemaker.
- Finer coffee grounds, such as drip and automatic drip coffeemaker (ADC) grinds, promote a full extraction of flavor and a rich, full-bodied coffee. Regular coffee grinds require slightly more coffee per cup to provide the strength of a finer coffee grind.
- Store unused ground coffee in a cool, dry place. After opening a package of ground coffee, reseal it tightly and store it in a refrigerator to maintain its freshness.
- For optimum coffee taste, buy whole coffee beans and finely grind them just before brewing.
- Do not reuse coffee grounds; this greatly reduces the coffee's flavor.
- Reheating coffee is not recommended as peak coffee flavor occurs immediately after brewing.
- Clean the coffeemaker when an oily build-up occurs. A small amount of oil on the surface of brewed coffee is due to the release of oil from roasted coffee beans. Oiliness may occur more frequently when using heavily-roasted coffees.

WARNING: Always unplug the product from the electrical outlet and allow the warming plate to cool completely before cleaning it.

• **NEVER:**

- Allow all of the contents to evaporate from the carafe
 - Heat the carafe when it's empty
 - Place the carafe on or near a hot gas or electric burner, in a heated oven, in a microwave oven or on a stovetop heating element
 - Handle the carafe roughly or expose it to sharp blows or impacts
 - Use abrasive scouring pads or cleansers to clean the product, as they may scratch/discolor the product's finish and/or weaken the carafe glass
- Discard and replace the carafe if it is damaged in any manner, as the carafe could break or contaminate the coffee with glass particles.
 - To clean the unit:
 - a. To clean the filter basket and the reusable mesh filter, remove them from the unit (See Figure 2, below). Clean the carafe and the carafe lid after each use. Wash in warm, soapy water. The filter, filter basket and carafe may also be placed in the top rack of a dishwasher to be cleaned.
 - b. Wipe exterior surfaces with a soft, damp cloth to remove stains.
 - c. Water droplets may build-up around the filter basket and drip onto the product base during brewing. To control the dripping, wipe the area with a clean, dry cloth after each use.

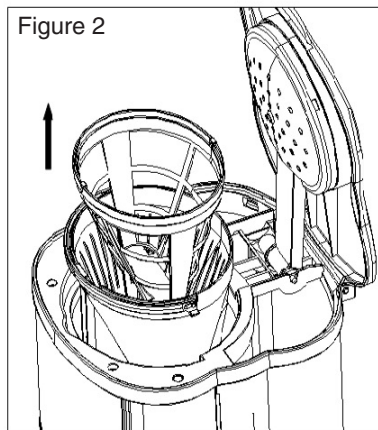

Mineral Deposits:

To keep your coffeemaker operating efficiently, clean away the mineral deposits left by the water. At least once a month, use a water and vinegar household cleaning solution as described below to prevent the build-up of mineral deposits. If the water in your area is especially high in minerals, clean your coffeemaker at least every two weeks. Frequently cleaning the coffeemaker may also improve brewed coffee flavor.

1. Add a water and white vinegar mixture
 - a. Fill the carafe with one part white vinegar and two parts cold water.
 - b. Pour the water and white vinegar mixture into the water reservoir.
 2. Insert the reusable mesh filter into the filter basket and position the carafe onto the warming plate.
 3. Press the On/Auto/Off button once.
- NOTE:** During cleaning, more steam occurs than when brewing coffee.
4. Once the Carafe is half-filled with water-vinegar mixture, press the On/Auto/Off button twice to shut the unit off.
 5. Wait about 15 minutes for the water-vinegar mixture to cool in the carafe, then pour the water-vinegar mixture back into the water reservoir.
 6. Press the On/Auto/Off button again. Allow ALL of the water-vinegar mixture to drip into the carafe.
 7. Once the water-vinegar mixture stops dripping, press the On/Auto/Off button twice to shut the unit off.
 8. Rinse the coffeemaker:
 - a. Discard the water-vinegar mixture from the carafe.
 - b. Rinse the coffeemaker by brewing a carafe of cold water.
 - c. Empty and wash the carafe, mesh filter and filter basket; rinse thoroughly and let dry.
 9. Wipe the unit's exterior surface with a dry cloth.

If any item, for any reason, does not meet your expectations, just return it to us. We'll gladly either:

- Refund your merchandise amount
- Credit your account
- Send a replacement

You can return any unused item in its original packaging within 60 days of its receipt for a full refund of the purchase price (excluding shipping and handling charges).

Please send returns to:

**Montgomery Ward, Inc.
Attn: Customer Returns
2000 Harrison Suite 100
Clinton, IA 52732-6676**

When returning an item:

- Use the original packaging and pack it securely.
- Please adequately insure your item in case you need to make a claim with the carrier you choose for returning your item.
- Include your order number and reason for return.
- We recommend keeping the receipt for 4 weeks.



1 Year Limited Warranty

Montgomery Ward, Inc. warrants this Chef Tested product to be free from defects in material and workmanship for one year from provable date of purchase.

Within this warranty period, Montgomery Ward will repair or replace, at its option, defective parts of this Chef Tested product at no charge, provided the product is returned, freight prepaid with proof of purchase to Montgomery Ward. Allow 2-4 weeks for return shipping.

This warranty does not cover improper installation, misuse, abuse or neglect on part of the owner. Warranty is also invalid in any case that the product is taken apart or serviced by an unauthorized service station.

This warranty gives you specific legal rights and they may vary from state to state.

THE FOREGOING WARRANTIES ARE IN LIEU OF ALL OTHER WARRANTIES AND CONDITIONS, EXPRESS OR IMPLIED, INCLUDING BUT NOT LIMITED TO THOSE OF MERCHANTABILITY OR FITNESS FOR A PARTICULAR PURPOSE.

Montgomery Ward Customer Service
8:00 am to Midnight CST, Monday through Friday

Wards.com 1-888-557-3848