

Chef[®]
TESTED ✓

by **Montgomery Ward**[®]

Chef[®]
TESTED ✓

Easy-to-use with substantial size and power

by **Montgomery Ward**[®]

1.0 cu. ft. Microwave Oven



MODEL: CTT47S (Black); CTT4R (Red)

Montgomery Ward Customer Service
1112 7th Avenue, Monroe, WI 53566
8:00 am to Midnight, Monday through Friday

Wards.com 1-888-557-3848

Outside Back Cover

Instruction Manual

Item No.: 46173
120V~, 60Hz, 1650W

Wards.com 1-888-557-3848

Outside Front Cover



Chef[®]
TESTED ✓

by **Montgomery Ward**[®]

Thank you for purchasing your Chef Tested 1.0 cu. ft. Microwave Oven by Montgomery Ward. Put through the paces by the experts, we guarantee that it will perform to the highest standard, time after time, with all the convenience, easy clean-up and durability you rely on from Wards.

Your new microwave has substantial size and power, and is designed to conveniently sit on your countertop. With easy-to-use controls, nine food settings, cook, cook by weight, speed defrost, defrost by weight, digital display and 12-hour timer, it makes heating and re-heating a breeze—whether it's a pot of chili or a plate of Thanksgiving day leftovers.

Glass tray is dishwasher safe.

Table of Contents

Important Safeguards.....	3-4
Precautions.....	5
Parts & Features.....	6
Control Panel Features.....	7
Installation	8
Grounding Instructions	8
Electrical Requirements.....	9
Utensils & Cooking Aids	10
Operating Instructions	11-15
Cleaning & Care	16
Troubleshooting	17
Cooking Guidelines & Tips	17
Warranty & Return Information.....	18-19

PLEASE SAVE THESE INSTRUCTIONS

THIS APPLIANCE IS FOR HOUSEHOLD USE ONLY

© 2015 Montgomery Ward, Inc. All rights reserved.

Important Safeguards

READ ALL SAFETY INSTRUCTIONS BEFORE USING THIS MICROWAVE.

WARNING: To reduce the risk of burns, electric shock, fire, injury to persons or exposure to excessive microwave energy, basic safety precautions should be followed, including the following:

1. Read and follow the specific "Precautions" section to avoid possible exposure to excessive microwave energy (page 5).
2. This appliance must be grounded. Connect only to a properly grounded outlet. See "Grounding Instructions" (page 8).
3. Install or locate this appliance only in accordance with the provided installation instructions.
4. Some products (such as whole eggs) and sealed containers (such as sealed glass jars) can explode and should not be heated in this microwave oven.
5. Use this appliance only for its intended use as described in this manual. Do not use corrosive chemicals or vapors in this appliance. This type of oven is specifically designed to heat or cook food.
6. This appliance is not intended for industrial or laboratory use.
7. As with any appliance, close supervision is necessary when used by children.
8. To reduce the risk of fire in the microwave oven:
 - a. Do not overcook food. Carefully attend appliance when paper, plastic or other combustible materials are used to aid cooking.
 - b. Remove wire twist-ties from paper or plastic bags before placing the bag in your microwave.
 - c. If materials inside the oven ignite, keep oven door closed, turn oven off and disconnect the power cord (or shut off power at the fuse or circuit breaker panel).
9. Liquids, such as water, coffee or tea can be overheated beyond the boiling point without appearing to be boiling due to surface tension of the liquid. Visible bubbling or boiling when the container is removed from the microwave oven is not always present.

This could result in very hot liquids suddenly boiling over when a spoon or other utensil is inserted into the liquid.

Important Safeguards (cont'd)

To reduce the risk of injury:

- a. Do NOT overheat the liquid.
 - b. Stir the liquid both before and halfway through heating.
 - c. Do not use straight-sided containers with narrow necks.
 - d. After heating, leave the container with liquid in the microwave for a short time (approx. 20 seconds) before removing.
 - e. Use extreme care when inserting a spoon or other utensil into hot liquid.
10. Do NOT heat oil or fat for deep-frying. It is difficult to control the temperature of oil in a microwave oven.
 11. Pierce foods with heavy skins (such as potatoes, whole squash, apples and chestnuts) before cooking.
 12. To avoid burns, the contents of feeding bottles and baby jars should be stirred or shaken, and the temperature should be checked.
 13. Cooking utensils may become hot because of heat transferred from heated food. Potholders may be needed to handle the utensil.
 14. Do NOT cover or block any openings on the appliance.
 15. Do NOT store or use this appliance outdoors. Do NOT use this product near water. Example: near a kitchen sink, in a wet basement, near a swimming pool or in similar locations.
 16. Do NOT operate this appliance if it has a damaged cord or plug, if it is not working properly or if it has been damaged or dropped.
 17. Do NOT immerse cord or plug in water. Keep cord away from heated surfaces. Do NOT let cord hang over edge of table or counter.
 18. Use only thermometers that are specifically designed for use in microwave ovens.
 19. Do NOT operate any heating or cooking appliance beneath this appliance.
 20. Be certain the Glass Tray, Roller Ring and Drive Shaft are in place when you operate the oven.
 21. Do NOT use the appliance if it arrives damaged or defective. Call our toll-free number for information.
 22. When cleaning adjoining surfaces of the door and oven (those that come in contact when closing the door), use only mild, nonabrasive soaps or detergents applied with a sponge or soft cloth.
 23. Use oven mitt or potholder after cooking for an extended period of time.

Precautions

To Avoid Possible Exposure to Excessive Microwave Energy:

1. Do NOT attempt to operate this oven with the door open. OPEN-DOOR OPERATION CAN RESULT IN HARMFUL EXPOSURE TO MICROWAVE ENERGY.
2. Do NOT tamper with the safety interlocks
3. Do NOT place any object between the oven front face and the door or allow any soil or cleaner residue to accumulate on sealing surfaces.
4. Do NOT operate the oven if it is damaged. It is particularly important that the oven door closes properly and that there is no damage to the following:
 - a. Door (cannot be bent)
 - b. Hinges and latches (cannot be broken or loosened)
 - c. Door seals and sealing surfaces (must be intact)
5. The oven should not be adjusted or repaired by anyone except properly qualified service personnel. Call our toll-free number for information.

Parts & Features

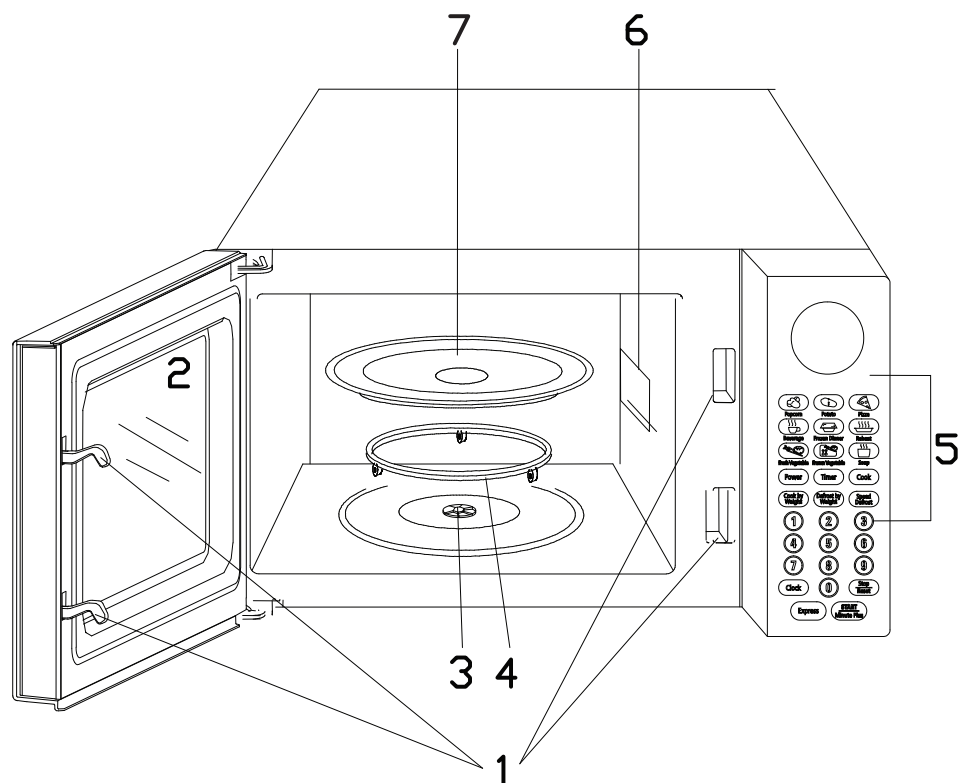

1. Door Safety Lock System
2. Oven Window
3. Shaft
4. Roller Ring
5. Control Panel
6. Wave Guide (Please do not remove)
7. Glass Tray

Control Panel Features

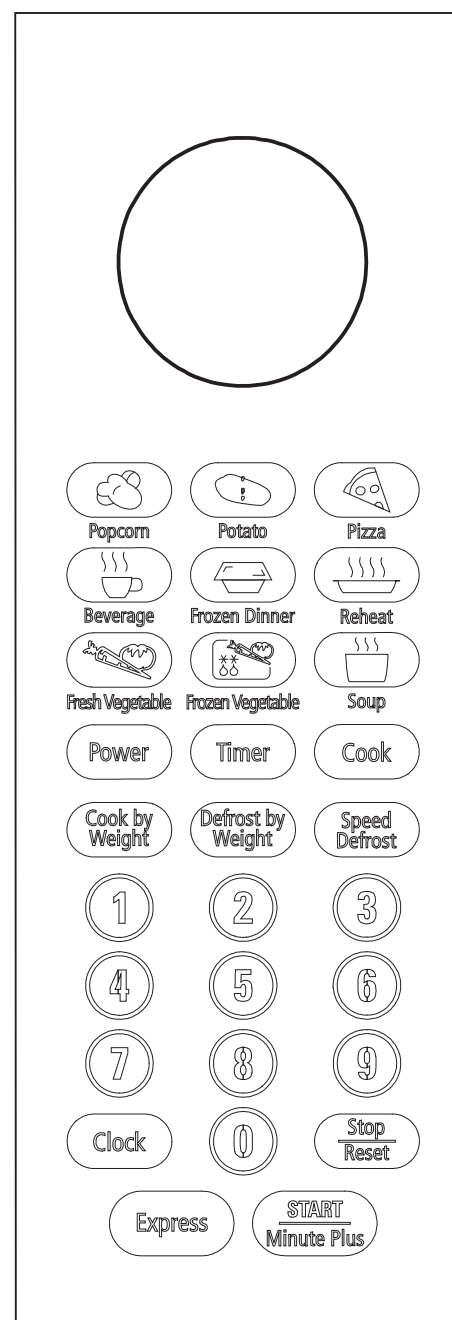

- **Menu Action Screen**
Cooking time, power, indicators and present time are displayed
- **Quick Cook Buttons**
Instant settings to cook popular foods
- **Power**
Use to set microwave power levels
- **Timer**
Timer functions independently, even while a cooking program is in process
- **Cook**
Use for multi-stage cooking; enables cooking at multiple power and time settings automatically
- **Cook by Weight**
Programmed cooking based on the weight of foods to be cooked
- **Defrost by Weight**
Programmed defrosting based on the weight of the foods to be defrosted
- **Speed Defrost**
Quick defrost function that alternates defrost and stand times to quickly and effectively defrost foods.
- **Number Pads (0-9)**
Touch to enter time or amount
- **Clock**
Set current time
- **Stop/Reset**
Press to cancel a setting or reset the microwave before setting a cooking program. Press once to temporarily stop cooking, or twice to cancel cooking altogether. It is also used for setting child lock.
- **Express**
Use this feature to program the oven to microwave food at 100% power
- **Start/Minute Plus**
Touch to start cooking or to add an extra minute to your cooking cycle

Installation

1. Make sure that all packing materials are removed from the inside of the door.
2. Check the microwave for any damage, such as a misaligned or bent door, damaged door seals or sealing surfaces, broken or loose door hinges and latches, or dents inside the oven or on the door. If there is any damage, contact Customer Service.
3. This microwave oven must be placed on a flat, heat-resistant, stable surface to hold its weight and the heaviest food likely to be cooked in the microwave.
4. Do NOT place the microwave where heat, moisture or high humidity are generated—or near combustible materials.
5. For correct operation, the oven must have sufficient airflow. Allow 8 inches of space above the oven, 4 inches at back and 2 inches at each side. Do NOT cover or block any openings on the appliance. Do NOT remove the microwave's feet.
6. Do NOT operate the microwave without the Glass Tray, Roller Ring and Shaft in their proper positions.
7. Make sure that the power supply cord is undamaged and does not run under the microwave or over any hot or sharp surface.
8. The socket must be readily accessible so that it can be easily unplugged in an emergency.

Grounding Instructions

This appliance must be grounded. In the event of an electrical short circuit, grounding reduces risk of electric shock by providing an escape wire for the electric current.

WARNING: Improper use of the grounding plug can result in a risk of electric shock.

Consult a qualified electrician if the grounding instructions are not completely understood, or if you are unsure whether the appliance is properly grounded.

1. Do NOT use an extension cord. If the power supply cord is too short, have an electrician install an outlet near the appliance.
2. If it is necessary to use an extension cord, use only a 3-wire extension cord that has a 3-blade grounding plug and a 3-slot receptacle that will accept the plug on the appliance. The marked rating of the extension cord shall be equal to or greater than the electrical rating of the appliance.

Electrical Requirements

Electrical requirements: 120-volt, 60-Hz, AC only, 20 amp.

It is recommended that a separate circuit serving only the microwave be provided. The microwave is equipped with a 3-prong ground plug. It must be plugged into a wall receptacle that is properly installed and grounded.

Power Supply Cord

1. A short power supply cord is provided to reduce risks resulting from entanglement in, or tripping over, a longer cord.
2. Longer cord sets or extension cords are available and may be used if care is exercised in their use.
3. If a long cord or extension cord is used:
 - a. The marked electrical rating of the cord set or extension cord should be at least as great as the electrical rating of the appliance.
 - b. The extension cord must be a grounding-type 3-wire cord, and the longer cord should not drape over the counter or tabletop where it can be pulled by children or tripped over unintentionally.

NOTE:

If you have any questions about the grounding or electrical instructions, consult a qualified technician.
We cannot accept any liability for damage to the oven or personal injury resulting from failure to observe the electrical connection procedures.

Radio or TV interference

Should there be any interference caused by the microwave oven to your radio or TV, check that the microwave oven is on a different circuit, relocate the radio or TV as far from the oven as possible, or check position and signal of receiving antenna.

RECOMMENDED UTENSILS AND COOKING AIDS

Wax paper: Use as a cover to prevent splattering

Microwaveable plastic wrap: Use to retain steam. Leave a small opening for some steam to escape and avoid placing wrap directly on the food

Paper towels and napkins: Use for short-term heating and covering; they absorb excess moisture and prevent splattering. Do not use recycled paper towels—they may contain metal and could ignite.

Paper plates and cups: Use for short-term heating at low temperatures. Do not use recycled paper which may contain metal and could ignite.

Microwaveable glass and dishware: Use microwave-safe glass and dishware for heating and cooking. Do not use if chipped or cracked—glass and dishware could explode.

NOTE: Do not place refrigerated glass or dishware directly in the microwave—refrigerated glass or dishware could crack. Instead, put food into a room-temperature dish and heat safely.

Plastic: Use only microwave-safe plastic. Other plastics may melt.

Microwave browning dish: Use to brown the exterior of smaller items such as steaks, chops or pancakes. Follow the directions provided with your browning dish.

Thermometers: Use only those labeled “microwave safe” and follow all directions. Check the food in several places. Conventional thermometers may be used on microwaved food once the food has been removed from the microwave.

NOT RECOMMENDED UTENSILS AND COOKING AIDS

Glass jars and bottles: Regular glass is too thin to be used in a microwave. It can shatter and cause damage and injury.

Paper bags: Do not use paper bags in microwave—they are a fire hazard (with the exception of popcorn bags that are designed for one-time use in microwaves).

Styrofoam plates and cups: Styrofoam can melt and leave an unhealthy residue on food.

Plastic storage and food containers: Use only microwave-safe containers. Containers such as margarine tubs can melt in the microwave.

Metal utensils: Metal utensils can damage your microwave. Remove all metal before cooking.

Setting the Clock:

1. Touch the CLOCK pad once
2. Use the Number Pads (0-9) to enter the correct time
3. Touch the CLOCK pad again

NOTE: This is a 12-hour clock. When the oven is first plugged in or when the power resumes after a power interruption, the display will show “ENTER CLOCK TIME”. If you prefer to not have the clock displayed, touch STOP/RESET.

Setting the Timer:

1. Touch TIMER
2. Enter the amount of time by using the Number Pads (0-9)
3. Touch START/MINUTE PLUS

NOTE: (1)Time countdown can be seen in the display before clock or cooking time is returned to display. (2)Touch TIMER and then touch STOP/RESET to cancel TIMER during timing process.

Microwave Cooking:

For microwave cooking, the longest cooking time is 99:99.

Select power level by pressing POWER button and number pads (see chart below). Press EXPRESS to go back to 100% power.

Number Pad	Cooking Power	Number Pad	Cooking Power
10	100%	4	40%
9	90%	3	30%
8	80%	2	20%
7	70%	1	10%
6	60%	0	0%
5	50%		

For example, suppose you want to cook for 1 minute at 60% of microwave power:

1. Use Number Pads to enter cooking time (1:00)
2. Press POWER once
3. Use Number Pads to enter power level (6)
4. Touch START/MINUTE PLUS

NOTE: During the cooking process, you can check current cooking power by pressing POWER

Speed Defrost:

The longest defrosting time is 99.99.

1. Touch SPEED DEFROST
2. Enter desired defrosting time using the Number Pads (0-9)
3. Touch START/MINUTE PLUS

NOTE: During defrosting time, the system will pause and sound beeps to remind user to turn food over. Then press START/MINUTE PLUS to resume defrosting.

**After setting Speed Defrost, microwave can be programmed to automatically switch to one- or two-stage cooking.

Speed Defrost Plus One-Stage Cooking:

1. Touch SPEED DEFROST
2. Enter desired defrosting time using the Number Pads (0-9)
3. Press COOK and enter desired cooking time using Number Pads (0-9)
4. Press POWER then use Number Pads (0-9) to select power level
5. Touch START/MINUTE PLUS

Speed Defrost Plus Two-Stage Cooking:

Use this setting for Speed Defrost and setting the cooking program at 2 different cooking power settings.

1. Touch SPEED DEFROST
2. Enter desired defrosting time using the Number Pads (0-9)
3. Press COOK and enter desired cooking time using Number Pads (0-9)
4. Press POWER then use Number Pads (0-9) to select power level
5. Press COOK and enter desired cooking time for 2nd stage cooking using Number Pads (0-9)
6. Press POWER and use Number Pads (0-9) to select 2nd stage power level
7. Touch START/MINUTE PLUS

**After total time elapsed, the system will sound beeps with "END" in display. The beeps will continue to sound every two minutes automatically until the door is opened or any pad is touched.

Express Cooking:

Pressing the EXPRESS button will create 30 seconds of cooking time at 100% power. Each additional press of the EXPRESS button will add an additional 30 seconds to the cook time.

Cook by Weight:

1. Touch COOK BY WEIGHT once
2. Press Number Pads 1-3 to select the one digit code (see table on next page)
3. Use the Number Pad to enter food weight
4. Touch START/MINUTE PLUS

Cook by weight code description:

CODE	TYPE	MAX. WEIGHT
1	Beef	6 lbs.
2	Chicken	6 lbs.
3	Pork	5 lbs. 4 oz.

NOTE:

**Meat must be defrosted at refrigerated temperature

**Weight must be in pounds and ounces

**Ounce weights less than 10 must be preceded by a "0". If a label gives weight in pounds only, change the fraction of a pound into ounces using the chart below.

POUND	OUNCES	POUND	OUNCES
Less than .03	0	.54 to .59	9
.03 to .09	1	.60 to .65	10
.10 to .15	2	.66 to .71	11
.16 to .21	3	.72 to .78	12
.22 to .27	4	.79 to .84	13
.28 to .34	5	.85 to .90	14
.35 to .40	6	.91 to .96	15
.41 to .46	7	.97 to .99	16
.47 to .53	8		

EXAMPLES:

- If the weight is 4.5 lbs., convert .5 lbs to ounces using the chart above (in this case, 8 oz.). You would then enter the weight as "408".
- If the weight is 4 lbs. 10 oz., you would enter "410" as the food weight.

** During cooking, the system will pause and sound beeps to remind user to turn food over. Press START/MINUTE PLUS to resume cooking.

** After total time has elapsed, the system will sound beeps with "END" in display. The beeps will continue to sound every two minutes automatically until the door is opened or any pad is touched.

** Let meat stand a few minutes before carving.

Defrost by Weight (maximum weight is 6 lbs.)

1. Touch DEFROST BY WEIGHT once
2. Use the Number Pad (0-9) to enter food weight
3. Touch START/MINUTE PLUS

NOTE:

- ** Weight must be in pounds and ounces. Ounce weight less than 10 must be preceded by a "0" (Examples: 4 lbs. 8 oz. is entered as "408", 4 lbs. 10 oz. is entered as "410"). If label gives weight in pounds only, change the fraction of a pound into ounces using the chart on the previous page.
- ** During defrosting program, the system will pause and sound beeps to remind user to turn food over. Then press START/MINUTE PLUS to resume defrosting.
- ** After total time elapses, the system will sound beeps with "END" in display. The beeps will continue to sound every two minutes automatically until the door is opened or any pad is touched.
- ** The highest entry you can make for weight is 5 lbs. 16 oz. ("516"). Any attempt to enter "600" or higher will result in a failed entry.

Multi-Stage Cooking:

The microwave oven can be programmed for up to 3 automatic cooking sequences (one speed defrost with two microwave cooking programs—See page 12—or two stages of microwave cooking program).

Suppose you want to set the following cooking program:

Microwave cooking followed by microwave cooking with a lower power level

1. Press COOK and enter desired cooking time using Number Pads (0-9)
2. Press POWER then use Number Pads (0-9) to select power level
3. Press COOK and enter desired cooking time for 2nd stage cooking using Number Pads (0-9)
4. Press POWER and use Number Pads (0-9) to select 2nd stage power level
5. Touch START/MINUTE PLUS

NOTE: Speed Defrost can only be set in the first stage. Cook by Weight, Express and Auto Cook cannot be set in multi-stage cooking mode.

Minute Plus:

MINUTE PLUS lets you add an extra minute to the current cooking cycle in the current cooking program. You can also use it to extend cooking time in multiples of one minute.

NOTE: To extend cooking time in multiples of one minute, touch START/MINUTE PLUS repeatedly (once for each additional minute).

You can use MINUTE PLUS during microwave cooking process.

Setting Child Lock:

The lock prevents unsupervised operation by children.

To set, press and hold STOP/RESET for 3 seconds. "LOCK" is indicated on the display.

To cancel, press and hold STOP/RESET for 3 seconds. "LOCK" indication disappears.

Quick-Cook Buttons:

Popcorn

1. Touch POPCORN

** POPCORN automatically sets the cooking time for a 3.5 oz. bag of microwave popcorn.

2. Touch START/MINUTE PLUS

NOTE: To change the popcorn time:

Touch POPCORN twice. "ENTER TIME" appears in display.

Touch Number Pads (0-9) to enter minutes and seconds.

Touch START/MINUTE PLUS. The maximum time you can set is 99:99.

This new cooking time will be set as the default until you reset it.

Baked Potato:

For small potatoes (4 to 6 oz. each)

1. Touch POTATO once
2. Enter number of potatoes (1-4)
3. Touch START/MINUTE PLUS

For large potatoes (8 to 10 oz. each)

1. Touch POTATO twice
2. Enter number of potatoes (1-4)
3. Touch START/MINUTE PLUS

Reheat:

1. Touch REHEAT
2. Touch START/MINUTE PLUS

Pizza:

Reheating a slice of pizza (5 oz.)

1. Touch PIZZA once
 2. Touch START/MINUTE PLUS
- Heating a whole pizza

1. Touch PIZZA twice
2. Touch START/MINUTE PLUS

Beverage:

For small cups (5–7 oz. each)

1. Touch BEVERAGE once
2. Enter number of cups (1–4)
3. Touch START/MINUTE PLUS

For larger coffee mugs (9–11 oz. each)

1. Touch BEVERAGE twice
2. Enter number of mugs (1–4)
3. Touch START/MINUTE PLUS

Frozen Dinner:

For small (7–9 oz.) frozen dinners

1. Touch FROZEN DINNER once
2. Enter number of entrées (1–2)
3. Touch START/MINUTE PLUS

For larger (10–12 oz.) frozen dinners

1. Touch FROZEN DINNER twice
2. Enter number of entrées (1–2)
3. Touch START/MINUTE PLUS

Fresh Vegetable:

For fresh vegetables (4–9 oz./serving)

1. Touch FRESH VEGETABLE once
2. Enter number of servings (1–6)
3. Touch START/MINUTE PLUS

Frozen Vegetable:

For frozen vegetables (4-9 oz./serving)

1. Touch FROZEN VEGETABLE once
2. Enter number of servings (1-6)
3. Touch START/MINUTE PLUS

Soup:

To prepare soup (7–9 oz./serving)

1. Touch SOUP once
2. Enter number of servings (1–4)
3. Touch START/MINUTE PLUS

Cleaning & Care

1. Turn off the microwave and remove the power plug from the wall outlet before cleaning.
2. Keep the inside of the microwave clean. When food splatters or spilled liquids adhere to microwave walls, wipe with a damp cloth. Mild detergent may be used if the microwave gets very dirty. Avoid the use of spray and other harsh cleaners—they can stain, streak or dull the door surface.
3. Outside surfaces should be cleaned with a damp cloth. To prevent damage to the operating parts inside the microwave, water should not be allowed to seep into the ventilation openings.
4. To remove any spills or splatters, use a damp cloth. Regularly wipe both sides of the door and window, the door seals and all adjacent parts. Do NOT use abrasive cleaners.
5. Do NOT allow the control panel to become wet. Unplug the microwave before cleaning the control panel. Use a soft, damp cloth.
6. If steam accumulates inside or around the outside of the microwave door, wipe with a soft cloth. This is normal, and may occur when the microwave is operated under high-humidity conditions.
7. It is occasionally necessary to remove the Glass Tray for cleaning. Wash the tray in warm, soapy water or in a dishwasher.
8. The Roller Ring and microwave floor should be cleaned regularly to avoid excessive noise. Simply wipe the bottom of the microwave with mild detergent. The Roller Ring may be washed in mild soapy water or in a dishwasher. When removing the Roller Ring for cleaning, be sure to replace in its proper position.
9. To remove odors and stuck-on splatters from your microwave: in a deep microwaveable bowl, combine 1 cup of water with the juice and rind of 1 lemon. Microwave for 5 minutes. Then wipe thoroughly and dry with a soft cloth.
10. When it becomes necessary to replace the microwave light, please consult an appliance dealer to have it replaced.
11. The microwave should be cleaned regularly. Any food deposits should be promptly removed. Failure to maintain a clean microwave could lead to deterioration of the inside surfaces of the microwave. This, in turn, could adversely affect the life of the appliance, and possibly result in a hazardous situation.
12. **In the event that you need to dispose of this microwave, please follow your municipality's rules for proper disposal.**

Troubleshooting

Before asking for service, please check the following:

1. Check to ensure the microwave is plugged in securely. If it is not, remove the plug from the outlet, wait 10 seconds and plug it in again securely.
2. Check for a blown circuit fuse or a tripped main circuit breaker. If these seem to be operating properly, test the outlet with another appliance.
3. Check to ensure that the control panel is programmed correctly and the timer is set.
4. Check to ensure the door is securely closed, engaging the door safety lock system. If the door is not properly closed, the microwave energy will not circulate properly.

Cooking Guidelines & Tips

Arrange your food:

For even microwave heating, place the thickest parts toward the outside of your dish.

Rearrange your food:

Rearrange food (like meatballs) halfway through cooking time by turning them over and move those in the center of the dish to the outside.

Take cover:

Covering your food prevents spattering and helps it to cook more quickly and evenly:

- Wax paper is a great option for routine heating.
- When heating something (like cheese) that might stick to other coverings, adding a microwave-safe lid to your microwave-safe container is perfect.
- If you use microwaveable plastic wrap, make sure to leave a place for steam to escape and avoid having the wrap touch your food.

NOTE: A few foods shouldn't be covered in the microwave—like cakes, cookies, fried foods or anything with breading. They can get soggy.

If you're working from a recipe that isn't written for a microwave, reduce the salt by 1/3, spices by 1/2 and water or cooking liquid by 1/4.

Returns

If any item, for any reason, does not meet your expectations, just return it to us. We'll gladly either:

- Refund your merchandise amount
- Credit your account
- Send a replacement

You can return any unused item in its original packaging within 60 days of its receipt for a full refund of the purchase price (excluding shipping and handling charges).

Please send returns to:

**Montgomery Ward, Inc.
Attn: Customer Returns
2000 Harrison Suite 100
Clinton, IA 52732-6676**

When returning an item:

- Use the original packaging and pack it securely.
- Please adequately insure your item in case you need to make a claim with the carrier you choose for returning your item.
- Include your order number and reason for return.
- We recommend keeping the receipt for 4 weeks.

Chef[®]
TESTED ✓

1 Year Limited Warranty

Montgomery Ward, Inc. warrants this Chef Tested product to be free from defects in material and workmanship for one year from provable date of purchase.

Within this warranty period, Montgomery Ward will repair or replace, at its option, defective parts of this Chef Tested product at no charge, provided the product is returned, freight prepaid with proof of purchase to Montgomery Ward. Allow 2-4 weeks for return shipping.

This warranty does not cover improper installation, misuse, abuse or neglect on part of the owner. Warranty is also invalid in any case that the product is taken apart or serviced by an unauthorized service station.

This warranty gives you specific legal rights and they may vary from state to state.

THE FOREGOING WARRANTIES ARE IN LIEU OF ALL OTHER WARRANTIES AND CONDITIONS, EXPRESS OR IMPLIED, INCLUDING BUT NOT LIMITED TO THOSE OF MERCHANTABILITY OR FITNESS FOR A PARTICULAR PURPOSE.

Montgomery Ward Customer Service
8:00 am to Midnight CST, Monday through Friday

Wards.com 1-888-557-3848