

**Montgomery<sup>®</sup>  
Ward**

**Montgomery<sup>®</sup>  
Ward**

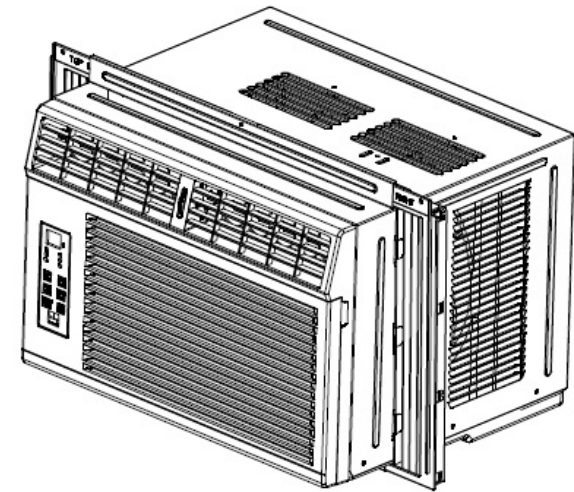

Window AC 12000BTU



## Instruction Manual

MODEL: MW12000  
115V~, 60Hz, 1060W

Montgomery Ward Customer Service  
3650 Milwaukee Street, Madison, WI 53714  
8:00 am to Midnight, Monday through Friday

Wards.com 1-888-557-3848

Wards.com 1-888-557-3848



Thank you for purchasing your Window Air Conditioner by Montgomery Ward®. We guarantee that it will perform to the highest standard, time after time, with all the convenience, easy cleanup and durability you rely on from Wards.

Your new 12000BTU air conditioner has an easy touch control panel with digital display. With the convenience of a remote control, you have control of your environment from anywhere in the room. Use Auto Mode to let the AC find and keep the right temperature without intervention from you. Cools rooms up to 450 square feet.

## Table of Contents

- Important Safeguards.....3-4
- 3-Prong Plug..... 4
- Installation .....4-10
- AC Removal ..... 11
- Operating Instructions ..... 11-14
- Cleaning and Care..... 15-16
- Troubleshooting ..... 17-18
- Warranty & Return Information.....20-21

### PLEASE SAVE THESE INSTRUCTIONS

THIS APPLIANCE IS FOR HOUSEHOLD USE ONLY

© 2015 Montgomery Ward, Inc. All rights reserved.

## Important Safeguards

### PLEASE READ THESE INSTRUCTIONS BEFORE USE

Basic safety precautions should always be followed when using your Window Air Conditioner especially when children are present.

**WARNING: TO AVOID THE RISK OF ELECTRICAL SHOCK, ALWAYS MAKE SURE THE PRODUCT IS UNPLUGGED FROM THE ELECTRICAL OUTLET BEFORE ASSEMBLING, DISASSEMBLING, RELOCATING, SERVICING OR CLEANING.**

1. Close supervision is necessary when any appliance is used by or near children.
2. Do not allow children or pets to be exposed to direct airflow for long periods of time.
3. To protect against electrical shock, do not place cord, plug or appliance in water or other liquid.
4. Use a dedicated circuit to avoid a power surge or overloading of the circuit.
5. Do not allow water to get on control panel or into any part of the unit.
6. Discard appliance following local ordinances.
7. Use the plug to disconnect from electrical outlet; never pull out by the cord.
8. Do not modify or alter the plug or power cord.
9. Turn power OFF before removing plug from outlet.
10. Never operate the appliance or remove the plug with wet hands.
11. Do not use an extension cord with this appliance.
12. Do not operate any appliance with a damaged cord or plug, or after the appliance malfunctions or has been damaged in any manner. Call our toll-free customer service number for information regarding replacement, or returning the product.
13. Do not remove front grill when machine is in use.
14. The back of the unit must be lower than the front of the unit to allow for adequate flow of condensation.
15. Do not block front grill, air inlet or outlet, or in any way restrict airflow.
16. Do not use abrasive cleansers or pads to clean air conditioner.
17. Remove batteries from remote control when not in use for long periods of time.
18. Do not unplug air conditioner when it is operating.
19. Use care when removing the filter. Do not touch metal parts of unit when removing filter.

## Important Safeguards (cont'd)

20. Before cleaning, turn power OFF and unplug from electrical outlet.
21. Do not insert body parts or tools into the inlet or outlet grills during operation.
22. Do not ingest water drained from air conditioner.
23. Do not store flammable or combustible liquids by unit.
24. Do not step or sit on air conditioner.
25. Do not store appliance on its side.
26. Do not use appliance for other than intended use.

## 3-Prong Plug

This appliance has a 3-prong GFCI (Ground Fault Circuit Interrupter) plug for use in a 3-prong (grounding) outlet to minimize the possibility of electric shock. This appliance should only be used with a 115V, 60Hz grounded outlet. Failure to follow these instructions could result in fire, electrical shock, serious injury or death.

If the plug does not fit fully in the outlet, contact a qualified electrician to install a 3-prong (grounding) outlet. Do not attempt to modify the plug in any way. Failure to follow these instructions could result in fire, electrical shock, serious injury or death.

## Installation

Your 12000BTU air conditioner is designed to be installed into standard double hung windows with an opening width of 24.0" - 39.0" and 14.5" vertical height.

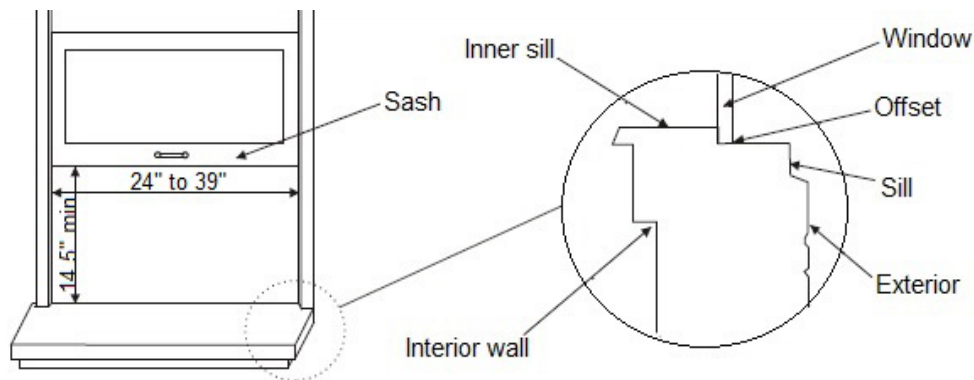

## Installation (cont'd)

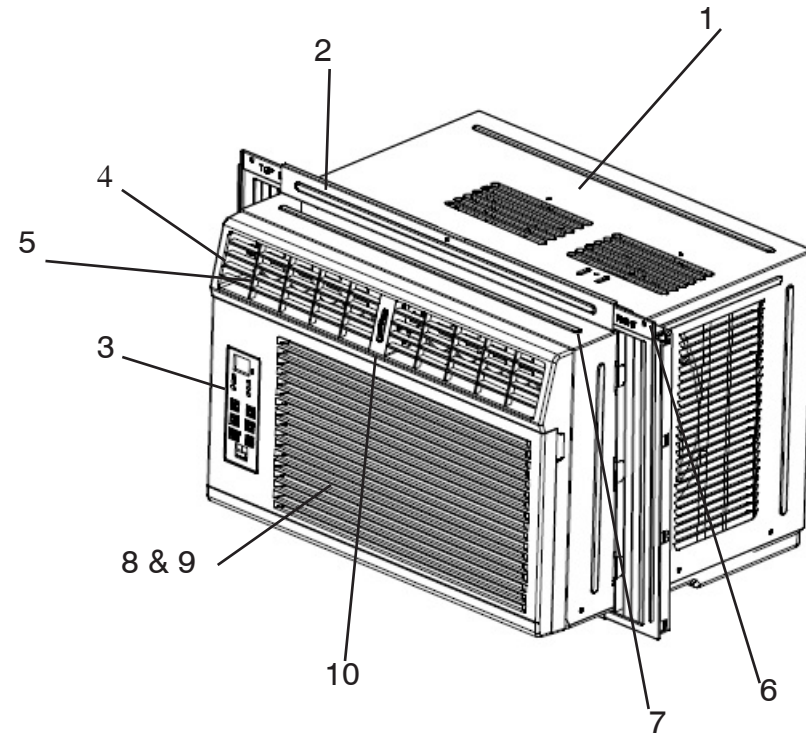

1. Cabinet
2. Upper guide
3. Control panel
4. Horizontal louver blades
5. Vertical louver blades
6. Guide panel
7. Front grill
8. Air filter
9. Air inlet
10. Air direction control

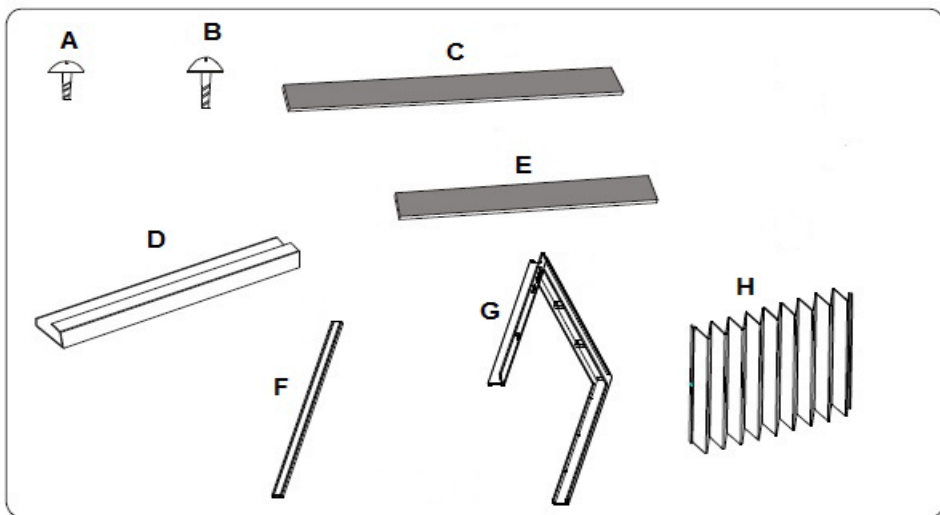

Item	Name of Part	Qty.
A	Screw (ST4X10FT)	4
B	Screw (ST4X16FT)	5
C	Foam Strip (Adhesive back)	1
D	Upper Guide	1
E	Foam Strip (Non-adhesive back)	1
F	Curtain Clip	2
G	Curtain Sash	2
H	Curtain	2

## Tools Required for Installation

- Gloves
- Standard screwdriver
- Pliers
- 3/8-inch adjustable wrench
- 1/4-inch hex socket and ratchet
- Tape measure
- Drill (if pilot holes are needed) with 1/4-inch drill bit

Remove air conditioning unit and accessories from box. Save box to use for storage of unit during the winter or when not in use for long periods of time.

## 1. Guide Panel Assembly:

Install the curtain (Item H) into the curtain sash (Item G) with the middle clip on the inside of the curtain sash. Then slide the curtain clip (Item F) on the end of the curtain sash to hold curtain in place.

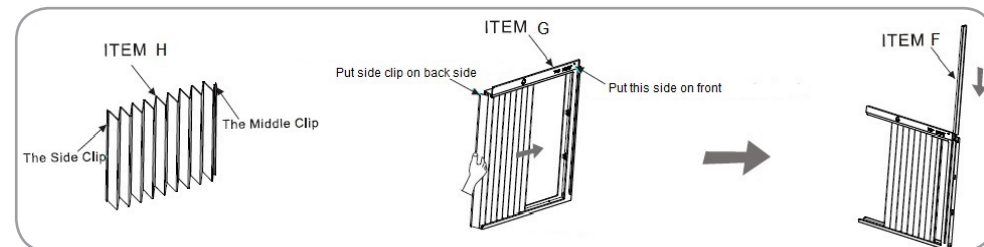

## 2. Upper Guide:

Secure the Upper Guide (Item D) to the top of the air conditioner using the 4 screws (Item A) provided.

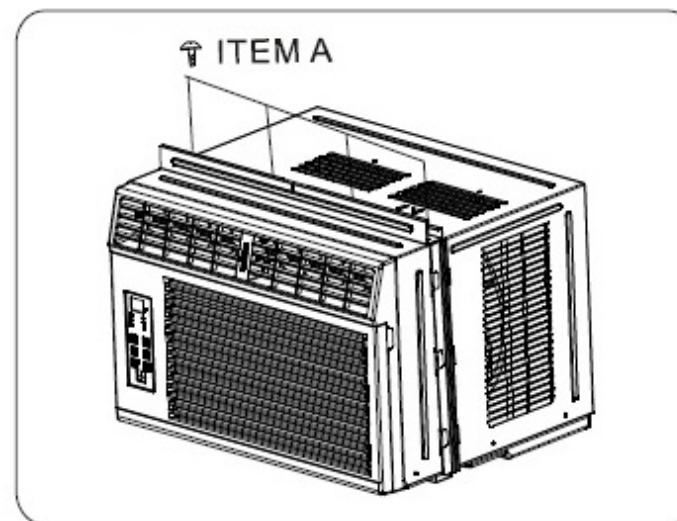

### 3. Guide Panels:

Extend the curtains in the guide panels and slide them down into the T-shaped groove on the left and right sides of the unit.

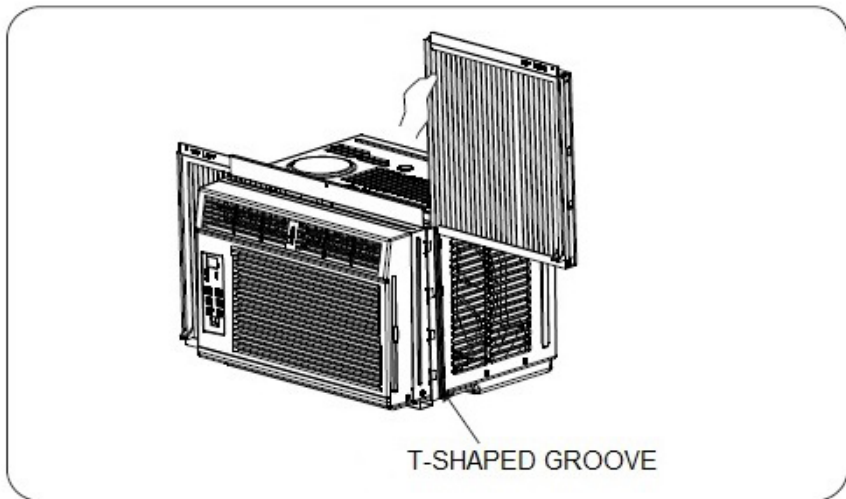

### 4. Foam Strip:

Cut the adhesive-backed foam strip (Item C) to the width of the window. Remove backing from foam and attach strip to the underside of the window.

### 5. Window Center:

With the window open, find and mark the center line of the inner sill.

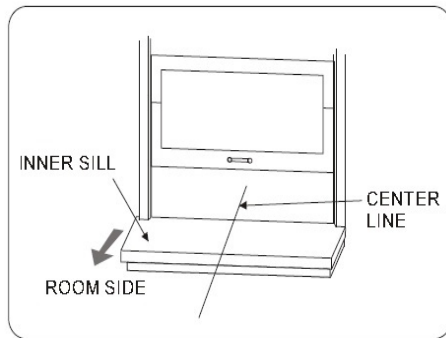
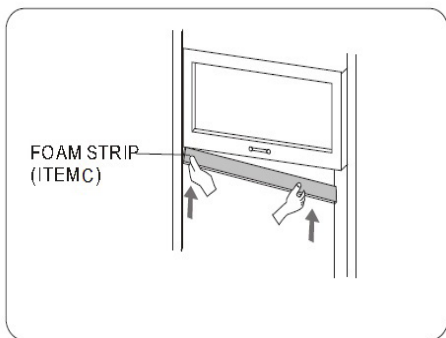

**CAUTION:** Hold unit firmly until window sash is lowered to top channel behind the upper guide. Personal injury or property damage may result if the air conditioner falls from the window.

### 6. Install Air Conditioner in Window:

Carefully fit the unit into the open window, lining up the center of the unit with the center line on the sill.

Firmly hold on to unit while lowering the window sash down *behind* the upper guide.

Extend guide panels to fill the open window and secure with 2 screws (Item B).

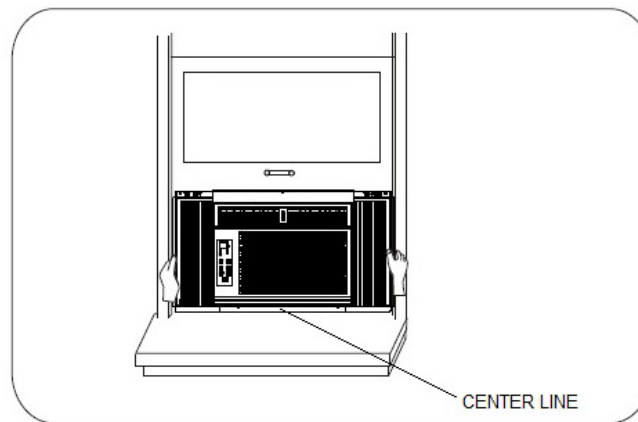

When the air conditioner is properly installed it should tilt back and down on the outside of the window. If it does not, there is a problem with the installation. Correct installation allows for proper drainage of the condensation.

## 7. Secure Guide Panels:

Fasten the top of the guide panels to the sash with 3 screws (Item B).

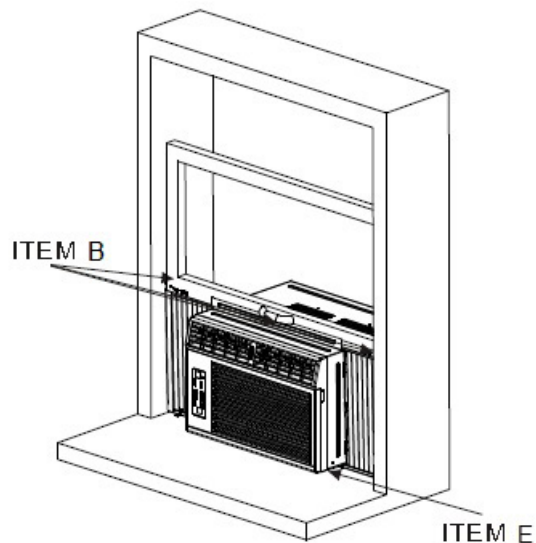

Insert foam strip (Item E) in the space between the window sill and the bottom of the air conditioner.

If AC is blocked by storm window frame, fasten a 2" wide wood strip to the inner window sill across the full width of the sill. The wood strip should be thick enough to raise the height of the window sill so that the unit can be installed without interference from the storm window frame (approximately 3/4-inch above storm window frame).

Install a second wood strip (approximately 6" long by 1 1/2" wide and the same thickness as the first wood strip) in the center of the outer sill. Place it flush against the back of the inner sill.

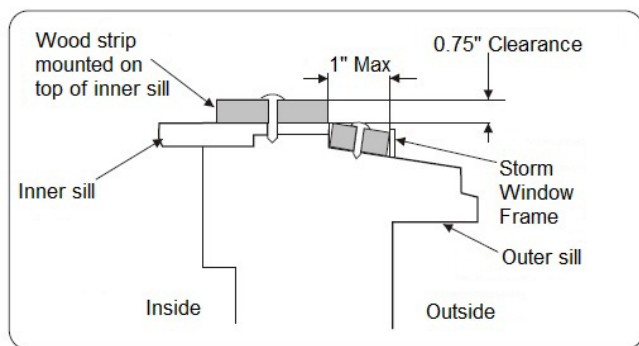

To remove air conditioner, turn power OFF and disconnect power cord. Remove the 5 screws installed in the top and bottom of the guide panels. Close guides and with a firm grip on the unit tilt outward to allow any condensation to drain out.

**CAUTION:** To avoid strain or injury to your back, use proper lifting and carrying techniques when moving air conditioner.

### To Store:

Be sure all parts are clean and dry before storing. Store appliance in original box.

# Operating Instructions

## Control Panel:

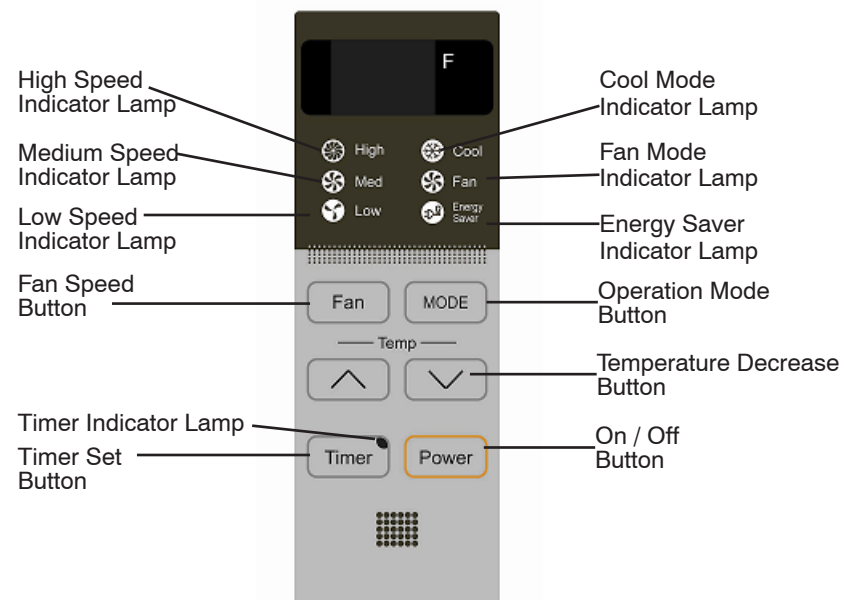

## Error Codes:

If the display on the control panel shows E1 or CF, it's time to clean the filter. If the display shows ER, EN or ED, call for service.

## Control Panel Functions:

Power - Use to turn AC ON and OFF.

**CAUTION:** After powering off the AC or switching from cooling to fan, wait a minimum of 3 minutes before turning cooling back on.

Fan Speed - Use to set fan speed by pressing the button to desired selection: Low > Medium > High > Low. A light will go on next to the selected speed.

Operation Mode - Use to switch between Cool > Energy Saver > Fan modes. The corresponding light will illuminate with your selection.

- Cool mode - When the temperature of the unit is set colder than the air temperature of the room, both the compressor and fan will run. But when the room temp becomes colder than what is set on the AC, only the fan will run.
- Energy Saver mode - At a set temperature, when the compressor stops the fan will automatically turn off. When the compressor starts again, the fan will turn on.
- Fan mode - The control panel displays the room temperature and only the fan will run, not the compressor.

Temperature Buttons - Use the up arrow to increase and the down arrow to decrease the temperature, which is displayed on the control panel. Every press of the button will increase or decrease the temperature by 1° F. The range of settings is 88° F to 61° F. Temperature controls only work in cooling mode.

Timer Set - Use this button to designate the number of hours (up to 24) the unit should run continuously until automatically shutting down *or* the number of hours until the unit automatically starts. Each press of the button increases the time, which is displayed on the control panel, by 1 hour. When the display reaches 24, pressing the Timer Set button again will cancel the timer.

To set number of hours for continuous operation, press Timer Set when the AC is ON. The display on the control panel will show the number of hours for 10 seconds and then display the set temperature. However, if in fan mode the temperature displayed will be that of the room.

To set the number of hours until the unit automatically powers up, press the Timer Set when the AC is OFF.

Air Flow Direction - Use the wheel on the front of the unit to adjust the louvers to direct air flow to the left, right or straight ahead.

## Remote Control:

To use the remote control, you must be within 20 feet of the unit with a clear line of sight. Remove batteries when control is not in use for long periods of time.

There are two functions on the remote control that are not available on the control panel on the air conditioning unit. They are as follows:

### 1. Auto Mode:

- When in this mode, the AC will set the temperature automatically based on the temperature of the room. For instance, when the room temperature is 79° F or higher, the AC defaults to Cool Mode and will set the temperature at 75° F.
- When the temperature in the room is lower than 79° F, the AC will set the temperature 4° F lower than the temperature in the room. If the room temp is 73° F the set temperature on the AC will be 69° F.

NOTE: During Auto Mode the set temperature cannot be manually adjusted and Sleep Mode is not available for use.

### 2. Sleep Mode:

- The AC must be in Cool Mode prior to using the Sleep Mode. When the Sleep Mode has been activated, the temperature set in the unit will increase 2° F one hour after Sleep Mode has been turned on and will increase another 2° F one hour after that. During Sleep Mode, the Fan Speed will automatically switch to LOW.

NOTE: Pressing the fan speed button while Sleep Mode is activated will deactivate Sleep Mode.

## Remote Control (cont'd)

**Increase Temperature**  
Only works in Cool Mode. Pressing and holding will increase temp 1° F every 0.6 seconds with range being 61° F - 88° F.

**Decrease Temperature**  
Only works in Cool Mode. Pressing and holding will decrease temp 1° F every 0.6 seconds with range being 61° F - 88° F.

**Power AC**  
On or Off.

**Operation Mode**  
Press to select Auto > Cool > Fan > Auto.

**Fan Speed**  
Press to change fan speed to Low > Medium > High > Auto > Low.

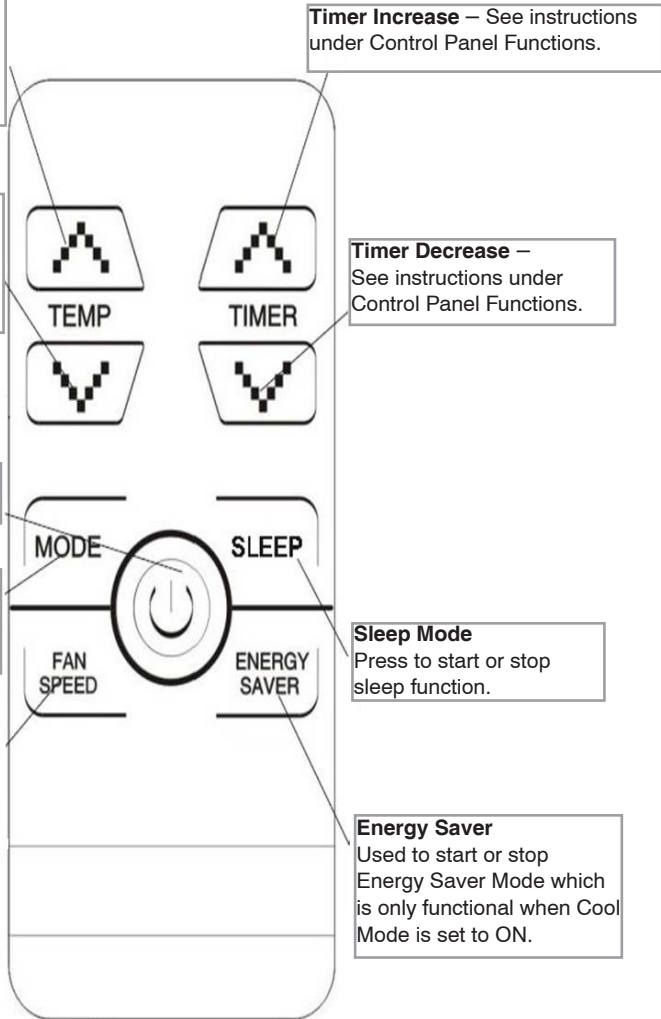

**WARNING:** Turn AC OFF and remove plug from outlet prior to cleaning.

## Air Filter Cleaning:

The air filter should be checked at least twice a month to see if cleaning is needed. Dust and dirt can build up in the filter and block airflow, which in turn decreases the cooling capacity and can cause an accumulation of frost on the cooling evaporator.

To clean the filter:

1. Using the handles on the left and right sides of the front grill pull the grill toward you at a 30° angle.
2. Remove the filter by lifting it straight up and out of the unit.
3. Wash filter under warm tap water. Do not soak or use any detergent. Shake off water before replacing filter.

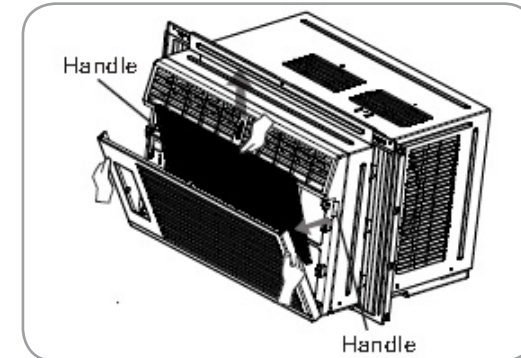

## Air Conditioner Cleaning:

Clean the front grill and air inlet by wiping with a soft cloth dampened with mild soap or detergent. The cabinet may also be washed with mild soap or detergent and lukewarm water.

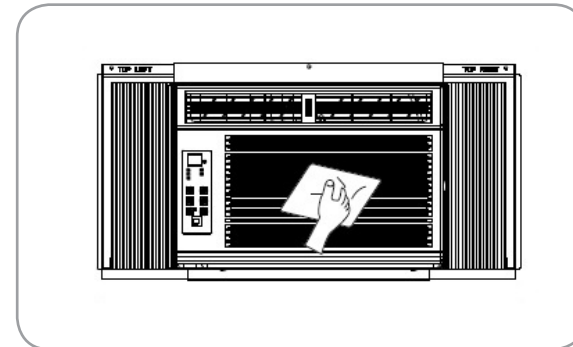



**WARNING:** Turn AC OFF and remove plug from outlet prior to cleaning.

## Front Grill Removal:

- Using the handles on the left and right sides of the front grill, pull the grill toward you at a 30° angle.

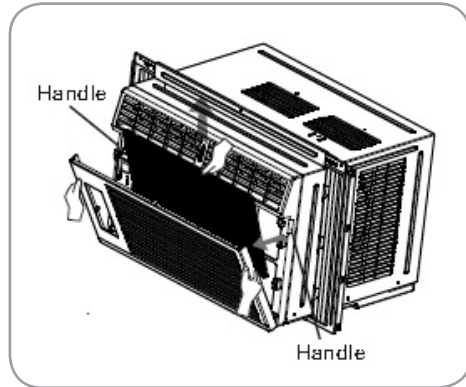

- Remove the filter by lifting it straight up and out of the unit.
- Unfasten the two screws holding the grill in place.
- Carefully push the grill down and pull away to release the tabs on the bottom.

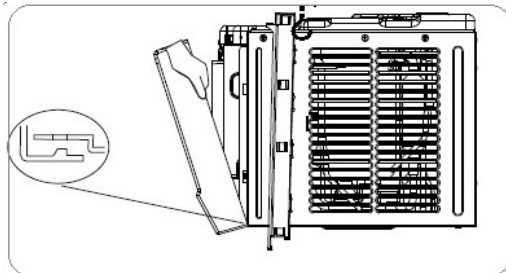

## Condenser Coil Cleaning:

To keep your air conditioner running at peak efficiency, the condenser coils on the back (outside) of the unit should be checked periodically for embedded debris. Brush or vacuum condenser coils to remove debris from fins.

Before calling service, try these troubleshooting tips.

Problem	Possible Cause	Remedy
Air conditioner will not operate.	Wall plug is loose or disconnected.	Confirm that plug is firmly pushed into socket.
	Fuse is blown or circuit breaker is tripped.	Replace fuse or reset circuit breaker.
	Unit was turned off and immediately turned back on.	Turn unit off and wait 3 full minutes before turning back on.
	Temperature set on unit is warmer than room temperature.	Lower the temperature on the AC.
Air from unit is not cool enough.	Fan speed is set too low.	Increase fan speed.
	Temperature on unit is too warm.	Lower temperature.
	Room temperature is below 61° F.	Cooling will not occur until room temperature is above 61° F.
AC is cooling, but room is warm and ice formed behind air inlet grill.	Temperature sensor tube is touching the evaporator coil.	Remove front grill and move sensor tube back into holding clip.
	Outdoor temperature is below 70° F.	To defrost coil, set the AC to fan mode.
AC rapidly turns on and off.	Air filter may be dirty.	Clean filter. Refer to Cleaning and Care section.
AC is emitting noises.	Outside temperature is extremely hot.	Set fan speed to high.
	Sounds like fan hitting water.	This is normal when humidity is high. Be sure all doors, windows and registers are closed.
	Sounds like gurgling or bubbling	This is the normal noise of gas passing through the condenser.

Problem	Possible Cause	Remedy
AC is cooling but room is still warm.	Air filter may be dirty.	Clean filter. Refer to Cleaning and Care section.
	Temperature on unit is too warm.	Increase temperature.
	Air flow is restricted.	Remove any obstacles (drapes, furniture, etc.) from in front of unit.

If any item, for any reason, does not meet your expectations, just return it to us. We'll gladly either:

- Refund your merchandise amount
- Credit your account
- Send a replacement

You can return any unused item in its original packaging within 60 days of its receipt for a full refund of the purchase price (excluding shipping and handling charges).

**Please send returns to:**

**Montgomery Ward, Inc.  
Attn: Customer Returns  
2000 Harrison Suite 100  
Clinton, IA 52732-6676**

**When returning an item:**

- Use the original packaging and pack it securely.
- Please adequately insure your item in case you need to make a claim with the carrier you choose for returning your item.
- Include your order number and reason for return.
- We recommend keeping the receipt for 4 weeks.



### 1 Year Limited Warranty

Montgomery Ward, Inc. warrants this product to be free from defects in material and workmanship for one year from provable date of purchase.

Within this warranty period, Montgomery Ward will repair or replace, at its option, defective parts of this product at no charge, provided the product is returned, freight prepaid with proof of purchase to Montgomery Ward. Allow 2-4 weeks for return shipping.

This warranty does not cover improper installation, misuse, abuse or neglect on part of the owner. Warranty is also invalid in any case that the product is taken apart or serviced by an unauthorized service station.

This warranty gives you specific legal rights and they may vary from state to state.

THE FOREGOING WARRANTIES ARE IN LIEU OF ALL OTHER WARRANTIES AND CONDITIONS, EXPRESS OR IMPLIED, INCLUDING BUT NOT LIMITED TO THOSE OF MERCHANTABILITY OR FITNESS FOR A PARTICULAR PURPOSE.

Montgomery Ward Customer Service  
8:00 am to Midnight CST, Monday through Friday

**Wards.com 1-888-557-3848**