



## INDOOR ELECTRIC SMOKER User Guide

Item: 749121

*Recipes  
Inside!*



***Ginnys.com • 800-544-1590***

** *Facebook.com/GinnysBrand***

** *Pinterest.com/GinnysBrand***

** *Ginnys.com/Blog***

---

---

Thank you for purchasing a Ginny's Brand Electric Smoker. If you love smoked food, you just made a great purchase! Now you can easily and quickly smoke food right on your kitchen countertop! From salmon to ribs to cheese and veggies — this little smoker will not disappoint. Enjoy!

---

---

## TABLE OF CONTENTS

Important Safeguards	3
Electrical Safety and Specifications	4
Get to Know Your Smoker	5
How to Operate	6-11
Cleaning & Care	11
Recipes	12-19
Warranty	20

# IMPORTANT SAFEGUARDS

## **READ CAREFULLY BEFORE USING AND SAVE THESE INSTRUCTIONS!**

- FOR HOUSEHOLD USE ONLY. Do not use this appliance for other than its intended use.
- REMOVE all packaging materials and labels before first use.
- WASH all removable parts before first use. See Cleaning & Care.
- A SHORT CORD is provided to reduce the hazards resulting from entanglement or tripping. Do not drape the cord over the counter or tabletop, where it can be pulled on or tripped over. Never wrap the cord tightly around the appliance, as this could cause the cord to fray or break.
- We do not recommend using an extension cord with this appliance. However, IF AN EXTENSION CORD IS USED, the marked electrical rating should be at least as great as the electrical rating of this appliance.
- CLOSE SUPERVISION is necessary when using this appliance near CHILDREN.
- A fire may occur if this appliance is used near FLAMMABLE MATERIALS, including curtains, towels, walls, etc. Do not place any paper, plastic, or other non-food items in the appliance. Do not place the appliance or its cord on or near a heated surface, or in a heated oven.
- This appliance should always be used on a STABLE, DRY, HEAT-RESISTANT SURFACE. Do not use near water.
- Do not use an accessory or attachment not recommended by Ginny's, as this may cause injury, or damage the appliance.
- Always use OVEN MITTS when handling hot food or appliances. Do not attempt to move an appliance when it is hot, or has hot contents.
- Do not use outdoors.
- Turn OFF AND UNPLUG this appliance when not in use.
- NO SERVICEABLE PARTS INSIDE THIS APPLIANCE.
- DO NOT USE AN APPLIANCE WITH A DAMAGED CORD OR PLUG, OR AFTER THE APPLIANCE MALFUNCTIONS, OR HAS BEEN DAMAGED IN ANY MANNER.
- **Do not smoke/cook food directly in the cooking pot! Always place food on rack(s).**
- DRY wood chips are recommended.

# ELECTRICAL SAFETY

This appliance is equipped with a three-prong grounding plug. This is a safety feature to reduce the risk of electrical shock. Using an extension cord is not recommended with this appliance. It is recommended that an electrical outlet serving ONLY this appliance be used. This outlet must be properly installed and grounded. If you have any questions about the grounding or electrical instructions, contact a qualified electrician. Do not attempt to modify the plug in any way. Ginny's cannot accept any liability for damage or injury resulting from failure to observe these safety procedures.

## SPECIFICATIONS

POWER RATING	500 W, 120 V, 60 Hz
CORD LENGTH	36"
DIMENSIONS	18" L x 11 3/4" W x 11 1/2" H
MODEL	MC95-S50

# GET TO KNOW YOUR SMOKER

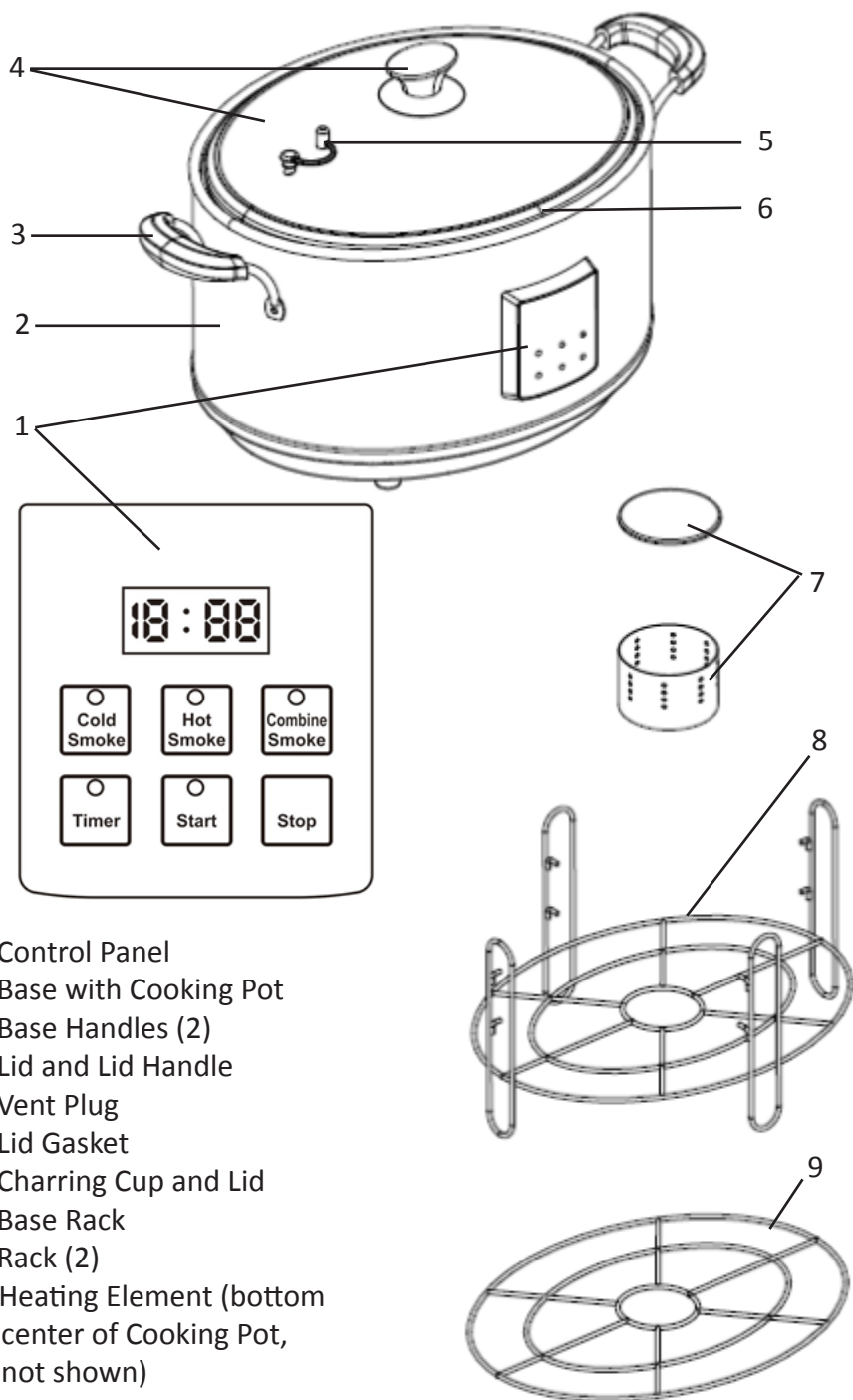

# HOW TO OPERATE

**WARNING:** Always use this smoker in a well ventilated area — preferably near an open window or an outside-vented stove hood. Do not use near a smoke detector or smoke alarm. The smoking process can be stopped at any time by pressing the STOP button.



Cooks the food while smoking. The temperature of the smoker will reach 248°F. Hot smoking can tenderize a tough cut of meat, but because the surface of the meat is being dried out, the smoke flavor does not penetrate far beyond the surface. Hot smoked meats can be brined, marinated, or have a rub applied to help maintain moisture through the smoking process.

1. Plug the cord into an outlet. The display will show "--:--".
2. Position the charring cup around the heating element. Place wood chips around the element in the charring cup. If cooking:
  - a. up to 2 hours, fill the cup about half full.
  - b. between 2-4 hours, fill the charring cup.
3. Place the lid on the charring cup. Add the base rack to the smoker.
4. Place the food on the rack(s).
5. Put the lid on the smoker (ensure the vent is plugged and the gasket is sealed around the rim), and set the desired smoking time by pressing HOT SMOKE, then TIMER. The display will count up 0:01 - 2:00 (hold the TIMER button down for rapid increase).
6. Press START to begin cooking. The display won't start counting down until the smoker heats up (may take a few minutes). The smoker may emit a little smoke as the cooking process goes on — this is normal. Try not to open the lid to check on your food, as this will allow smoke to escape.
7. When the cooking/smoking time has elapsed, 3 beeps will sound and the smoker will turn off. Remove the lid. If cooking meat, ALWAYS check for doneness with a meat thermometer (see table on page 7). Add more time if needed using HOT SMOKE.
8. While wearing oven mitts, remove the food from the cooker by lifting out the rack(s). Unplug the smoker.

(continued on page 7)

# HOW TO OPERATE

**Note:** When smoking meat, the smoking *time* is not as important as the *internal temperature of the meat*. You will find that this Ginny's smoker works much faster than traditional smoking methods. **Please monitor temperatures closely to avoid undercooked or overcooked food!**

Food	Internal Temperature
Beef Brisket	190-200°F
Beef Roast	190-200°F
Beef Ribs	190-200°F
Beef Country Style Ribs	175-180°F
Beef Meatloaf/Burger	160°F
Beef Steak	135°F (med. rare)
Beef Prime Rib	130-135°F (med. rare)
Pork Butt Roast (for pulled pork)	205°F
Pork Ribs	180-185°F
Pork Tenderloin	145°F
Whole Chicken	165°F
Chicken Legs/Wings/Thighs	165°F
Turkey Breast	165°F
Turkey Legs	175-180°F
Salmon Fillet	145°F
Tilapia Fillet	145°F
Whole Trout	145°F
Oysters	done when edges curl
Shrimp	done when curled to "C"
Hotdogs	175-180°F

# HOW TO OPERATE



Smokes food that is already cooked, or you will cook later. The temperature of the smoker will reach 140°F. Cold smoking will completely permeate the food with smoky flavor, but does not dry out the surface of the food. **Cold smoking does not cook foods.**

1. Plug the cord into an outlet. The display will show "--:--".
2. Position the charring cup around the heating element. Place wood chips around the element in the charring cup. If cooking:
  - a. up to 2 hours, fill the cup about half full.
  - b. between 2-4 hours, fill the charring cup.
3. Place the lid on the charring cup. Add the base rack to the smoker.
4. Place the food on the rack(s).
5. Put the lid on the smoker (ensure the vent is plugged and the gasket is sealed around the rim), and set the desired smoking time by pressing COLD SMOKE, then TIMER. The display will count up 0:01 - 2:00 (hold the TIMER button down for rapid increase).
6. Press START to begin cooking. The display won't start counting down until the smoker heats up (may take a few minutes). The smoker may emit a little smoke as the cooking process goes on — this is normal. Try not to open the lid to check on your food, as this will allow smoke to escape.
7. When the smoking time has elapsed, 3 beeps will sound and the smoker will turn off. Remove the lid. (Add more time if needed using COLD SMOKE.)
8. While wearing oven mitts, remove the food from the smoker by lifting out the rack(s). Unplug the smoker.

(continued on page 9)



# HOW TO OPERATE

**Note:** The possibilities are unlimited for cold smoking foods. The table below shows some of the foods we tried. Times may vary depending on thickness of the food or the wood chips you use.

Food	Cold Smoking Time
Garlic Head (slice the top off)	$\frac{3}{4}$ -1 hour
Mushrooms	$\frac{1}{2}$ hour
Nuts	$\frac{1}{2}$ hour
Onion (halved)	$\frac{1}{2}$ -1 hour
Sea Salt	1-2 hours
Tofu (drained and pressed)	1-1 $\frac{1}{2}$ hours
Tomato (halved)	$\frac{1}{2}$ - 1 hour

**Tip:** It is fine to put small items, or items that may drip, on aluminum foil on top of the rack(s) in the smoker.

# HOW TO OPERATE



Cold smokes the food first (to permeate with smoky flavor), then hot smokes the food (to cook and seal in the flavor). Recommended for larger cuts of meat.

1. Plug the cord into an outlet. The display will show "--:--".
2. Position the charring cup around the heating element. Place wood chips around the element in the charring cup. If cooking:
  - a. up to 2 hours, fill the cup about half full.
  - b. between 2-4 hours, fill the charring cup.
3. Place the lid on the charring cup. Add the base rack to the smoker.
4. Place the food on the rack(s).
5. Put the lid on the smoker (ensure the vent is plugged and the gasket is sealed around the rim), and set the desired smoking time by pressing COMBINE SMOKE, then TIMER. The display will count up 0:30- 4:00 (hold the TIMER button down for rapid increase).
6. Press START to begin cooking. The display won't start counting down until the smoker heats up (may take a few minutes). The smoker may emit a little smoke as the cooking process goes on — this is normal. Try not to open the lid to check on your food, as this will allow smoke to escape.
7. When the cooking/smoking time has elapsed, 3 beeps will sound and the smoker will turn off. Remove the lid. If cooking meat, ALWAYS check for doneness with a meat thermometer. (Add more time if needed using HOT SMOKE.)
8. While wearing oven mitts, remove the food from the cooker by lifting out the rack(s). Unplug the smoker.

(continued on page 11)

# HOW TO OPERATE

**Note:** The table below shows the breakdown between cold and hot smoke times when COMBINE SMOKE is selected:

Combine Smoke Time	Cold Smoke Time	Hot Smoke Time
:30	:12	:18
1:00	:24	:36
1:30	:36	:54
2:00	:48	1:12
2:30	1:00	1:30
3:00	1:12	1:48
3:30	1:24	2:06
4:00	1:36	2:24

## CLEANING & CARE

1. Turn off and unplug the smoker.
2. Always allow the appliance to cool completely before cleaning.
3. Remove the gasket from the lid and hand wash both in hot, soapy water. Dry completely and reassemble the lid and gasket.
4. Remove the rack(s). Remove the charring cover and cup.
5. Remove the wood chips. **Always soak the chips in water before discarding to avoid a fire hazard.**
6. Soak the rack(s), charring cover and charring cup in hot, soapy water to remove grease build-up. Wash and dry. These items are also dishwasher safe.
7. Use a soft cloth, sponge or rubber spatula to remove any stuck-on food or residue in the pot. Use a paper towel to wipe out excess grease.
8. Wash the pot with hot, soapy water, using a soft cloth. Rinse and dry. **Do not place in dishwasher, or immerse in water.** Do not use abrasive brushes or pads, or harsh cleaning solutions.
9. Wipe the exterior with a damp cloth.
10. Ensure all parts are dried thoroughly before reassembling and using this smoker.

## *Smoked Pesto and Olive Pizza*

I used pre-made naan bread for my crust – it fit really well in the smoker and made a nice, rustic crust. However, if you do not have that available locally, you may also use flat bread, French bread or even a tortilla for the crust. Feel free to experiment with your toppings – the combinations are endless!

1-2 t. pesto	4-5 Kalamata olives, chopped
1 small pre-made crust	½ Roma tomato, sliced thin
1 t. onion, minced	½ c. mozzarella, shredded
small handful of baby greens, chopped	mesquite or hickory wood chips

1. Brush the pesto onto the top of the crust using a pastry brush.
2. Spread on the onion and greens, olives and tomatoes. Top with the cheese.
3. When ready to smoke, fill the charring cup about halfway with dry woodchips and add the cover. Put the rack in the smoker, add the pizza and lid.
4. HOT SMOKE for 15-20 minutes or until the cheese is nicely melted.
5. Serve hot.

Serves 1-2

# RECIPES

## *Smoked Pulled Pork*

3-4 lb. pork shoulder roast	½ t. pepper
1 qt. apple juice	1 T. paprika
2 T. sugar	1 ½ t. onion powder
¼ c. brown sugar	1 ½ t. garlic powder
2 T. salt	hickory wood chips

1. Place pork in a pot or bowl and cover with the apple juice.
2. In a small bowl, mix remaining ingredients except the wood chips. Stir well – this will make your “rub” and “brine”. Divide in half. Add one half to the bowl of apple juice and roast, and retain the other half in a covered container.
3. Flip the roast a few times to stir up the brine. Cover and refrigerate 8 hours or overnight.
4. When ready to smoke, fill the charring cup full with dry hickory chips and add the cover. Put the rack in the smoker.
5. Remove the roast from the brine and dry with a paper towel. Liberally pat on the remaining rub to cover the roast. Place the roast on the rack in the smoker and cover with the lid.
6. COMBINE SMOKE for 4 hours (about 1 ½ hours on cold, then 2 ½ hours on hot). When done, the roast should have an internal temperature of 205°F. If it needs to cook longer, set HOT SMOKE for 15-30 more minutes.
7. Using oven mitts, remove the rack with the roast. It should be tender and falling apart. Let rest for at least 10 minutes before shredding with two forks on a platter or cutting board.
8. Serve on buns with mustard or barbeque sauce.

Serves 6-8

## *Smoked Turkey Breast*

3 c. apple juice	¼ t. sage
¼ c. salt	1 T. garlic, minced
¼ c. sugar	2-3 lb. boneless turkey breast
¼ c. apple cider vinegar	hickory wood chips
¼ t. thyme	

1. Mix the first 7 ingredients in a medium bowl and stir well to make brine. Add the turkey. If needed, add a little water so the brine completely covers the turkey.
2. Cover the bowl and refrigerate 8 hours or overnight.
3. When ready to smoke, place the dry chips in the charring cup (fill the cup full) and cover. Add the rack to the smoker.
4. Remove the turkey from the brine and pat dry with paper towels. Place the turkey on the rack. Put on the lid and cook on **COMBINE SMOKE** for 2½ hours (about 1 hour on cold and 1 ½ hours on hot), until internal temperature reaches 165° F. If the meat needs to cook longer, set **HOT SMOKE** for 10-15 more minutes.
5. When finished, remove the turkey breast by lifting it off the rack with 2 forks. Place it on a cutting board and wrap it in foil for 15 minutes before slicing.

Serves 4-6

# RECIPES

## THE BEST Smoked Ribs

4 lb. pork ribs	1 T. pepper
3 T. salt	1 T. paprika
1 T. sugar	1 T. onion powder
2 T. brown sugar	1 T. garlic powder
1 T. ground cumin	mesquite wood chips
1 T. chili powder	¼ c. barbeque sauce (or more to taste)

1. If there is a thin membrane on one side of the ribs, peel up a corner, and using a paper towel to grip, pull the membrane off and discard. Cut the meat into pieces about 3-4 ribs wide so they will fit easily in the smoker (they'll also be easier to serve this way).
2. In a small bowl, mix remaining ingredients except the wood chips and barbeque sauce. Stir well – this is your “rub”.
3. Pat the ribs with water, then with the rub. Coat all sides well and place in a shallow dish. Cover the meat tightly with plastic wrap and refrigerate 8 hours or overnight.
4. When ready to smoke, fill the charring cup full with dry mesquite chips and add the cover. Put the rack in the smoker.
5. Do NOT rinse the ribs. Place them on the rack - you should use at least two racks to fit all the ribs in the smoker – make sure there is space between the racks for the smoke to circulate well. Cover with the lid.
6. COMBINE SMOKE for 4 hours (about 1 ½ hours on cold, then 2 ½ hours on hot). When done, the meat should be pulling away from the bones and have an internal temperature of 180°F. If the meat needs to cook longer, set HOT SMOKE for 10-15 more minutes.
7. Using oven mitts, remove the rack with the ribs.
8. Serve with barbeque sauce and lots of napkins.

Serves 2-4

# RECIPES

## *Chicken Salad with Smoked Grapes and Walnuts*

mesquite wood chips	¼ c. onion, minced
2 c. red, seedless grapes	1 ½ c. mayonnaise
2 c. walnuts, chopped	salt & pepper
3 c. chicken, cooked and chopped	

1. Fill the smoker charring cup about half full with dry wood chips and cover. Place the rack in the smoker.
2. Put aluminum foil on the rack and add the grapes. Place a second rack in the smoker, with foil, and add the walnuts. Cover and COLD SMOKE for ½ hour.
3. When smoking is finished remove the nuts and grapes. Slice the grapes in half.
4. In a large bowl, combine all ingredients and stir to blend. Salt & pepper to taste.
5. Serve on buns or over leafy greens.

Makes about 7 cups

## *Smoked Cheese*

We experimented with a few different cheeses, and did see some melting, so do not expect your block of cheese to come out smoked and perfectly square. We had the most luck with semi-hard cheeses like Gruyere and Gouda. Bleu cheese held up remarkably well also. Even when we did see some melting (cheddar and Fontina), the end result was still delicious!

1. Fill the smoker charring cup about half full with dry hickory or mesquite wood chips and cover. Place the rack in the smoker.
2. Put aluminum foil on the rack and add *room-temperature* cheese. (Use 2 racks, if needed.) Cover and COLD SMOKE for ½ - 1 hour.
3. When smoking is finished remove the cheese. Blot dry with paper towels and wrap tightly in plastic wrap. Refrigerate for at least 24 hours to get the best, smoky flavor.



## *Smoked Salsa*

mesquite wood chips	1 c. cilantro, stemmed
6 Roma tomatoes, halved and seeded	¼ t. ground cumin
½ large sweet onion, halved and peeled	juice from half a lime
1 large jalapeno, halved and seeded	salt & pepper

1. Fill the smoker charring cup about half full with dry wood chips and cover. Place the rack in the smoker.
2. Put aluminum foil on the rack and add the tomatoes. Place a second rack in the smoker and add the onion and jalapeno. Cover and COLD SMOKE for ½ hour.
3. When smoking is finished remove the tomatoes, onion and pepper with tongs.
4. With a food processor, pulse the tomatoes and onion. Add the pepper and cilantro and pulse until desired consistency is reached. Stir in the cumin and juice. Add salt & pepper to taste.
5. Serve with tortilla chips, or use as a taco topping.

Makes about 2 cups

## *Smoked Chicken*

mesquite or hickory wood chips  
5 lb. whole chicken  
salt & pepper

1. Fill the smoker charring cup about half full with dry wood chips and cover. Place the rack in the smoker.
2. Pat the chicken dry, inside and out, with paper towels. Sprinkle generously with salt and pepper.
3. Cover and HOT SMOKE for 1-1½ hours (until meat temperature reaches 165°F).
4. When smoking is finished remove the chicken using 2 forks. Cover loosely with aluminum foil and let chicken rest for 1/2 hour before serving.

Serves 4

## *Smoked Salmon*

1 lb. salmon fillets, cut into 4 pieces	1 T. pepper
2 c. water	¼ c. salt
2 T. sugar	mesquite or hickory wood chips
1 T. garlic powder	

1. Place all ingredients in a shallow dish (add a little more water if needed to cover the salmon). Flip the fillets a few times to mix the brine. Refrigerate for 2 hours.
2. Fill the charring cup about half full with wood chips and cover. Place the rack in the smoker.
3. Remove the salmon from the brine and pat dry. Place the fillets on the rack, cover and HOT SMOKE for 45-60 minutes, or until internal temperature reaches 145°F. Add a few more minutes if needed.
4. When done, remove the salmon with a spatula and serve hot or cold with crackers.

Serves 2-4

# RECIPES

## *Smoked Corn on the Cob*

4 ears of corn	salt & pepper
2 T. butter, softened	chili powder
1 T. lemon juice	hickory or mesquite wood chips

1. Peel back the leaves (but do not pull off) and remove the silk from each ear of corn.
2. In a small bowl, mix the butter and juice. Add the salt, pepper and chili powder to taste. Stir well until blended. Spread this mixture on the corn and fold the leaves back to cover. Use twine or rubber bands to secure the leaves, if needed.
3. Soak corn 1 hour in water in the refrigerator.
4. Fill the smoker charring cup about half full with dry wood chips and cover. Place the rack in the smoker.
5. Remove the corn from the water and pat outside dry with a towel. Discard the rubber bands or twine.
6. Cover and HOT SMOKE for 1 hour. When smoking is finished, remove the corn with tongs and let rest for 10 minutes.
7. Peel back the leaves and serve. Enjoy!

Serves 4

# WARRANTY

Ginny's warrants this product free from defects in material and workmanship for one year from provable date of purchase.

Within this warranty period, Ginny's will repair or replace, at its option, defective parts at no charge, provided the product is returned, freight prepaid with proof of purchase to Ginny's. Allow 2-4 weeks for return shipping.

This warranty does not cover improper installation, misuse, abuse or neglect on part of the owner. Warranty is also invalid in any case that the product is taken apart or serviced by an unauthorized service station.

This warranty gives you specific legal rights and they may vary from state to state.

THE FOREGOING WARRANTIES ARE IN LIEU OF ALL OTHER WARRANTIES AND CONDITIONS, EXPRESS OR IMPLIED, INCLUDING BUT NOT LIMITED TO THOSE OF MERCHANTABILITY OR FITNESS FOR A PARTICULAR PURPOSE.



Ginny's, Inc.  
1112 7th Avenue  
Monroe, WI 53566

Customer Service: 800-544-1590  
8:00 a.m. to Midnight CST, Monday through Friday