

Montgomery Ward™

Montgomery Ward™

Easy-to-use with substantial size and power

1.0 cu. ft. Microwave Oven



Instruction Manual

MODEL: FC102R_MW
120V~, 60Hz, 900W

Montgomery Ward Customer Service
3650 Milwaukee Street, Madison, WI 53714
8:00 am to Midnight, Monday through Friday

Wards.com 1-888-557-3848

Wards.com 1-888-557-3848



Thank you for purchasing your Microwave Oven by Montgomery Ward™. We guarantee that it will perform to the highest standard, time after time, with all the convenience, easy cleanup and durability you rely on from Wards.

Your new microwave has substantial size and power, and is designed to conveniently sit on your countertop. With easy-to-use controls, including six food settings, cook, defrost, weight defrost, memory, digital display and timer, it makes heating and re-heating a breeze—whether it's last night's leftovers or frozen veggies for tonight's dinner. Glass tray is dishwasher safe.

Table of Contents

- Important Safeguards..... 3–4
- Installation Guide..... 5
- Installing the Turntable..... 5
- Grounding Instructions 6
- Parts & Features..... 7
- Control Panel..... 8
- How to Use 9–13
- Cooking Utensil Guide..... 14
- Cooking Techniques 15
- Cleaning & Care 16
- Troubleshooting 17
- Warranty & Return Information..... 18–19

PLEASE SAVE THESE INSTRUCTIONS

THIS APPLIANCE IS FOR HOUSEHOLD USE ONLY

© 2014 Montgomery Ward, Inc. All rights reserved.

Important Safeguards

PLEASE READ THESE INSTRUCTIONS BEFORE USE

To reduce the risk of burns, electric shock, fire, injury to persons or exposure to excessive microwave energy, basic safety precautions should be followed, including the following:

WARNING: TO AVOID THE RISK OF ELECTRICAL SHOCK, ALWAYS MAKE SURE THE PRODUCT IS UNPLUGGED FROM THE ELECTRICAL OUTLET BEFORE ASSEMBLING, DISASSEMBLING, RELOCATING, SERVICING OR CLEANING

1. Read and follow the “Precautions to Avoid Possible Exposure to Excessive Microwave Energy” on p. 4.
2. The microwave must be grounded. Connect only to properly grounded outlets. See p. 6 for grounding instructions.
3. Install or place this microwave only in accordance with the installation instructions.
4. Some produce, such as whole eggs, and sealed containers and closed jars are able to explode and should not be heated in this oven.
5. This microwave is intended for use only as described in this manual. Do NOT use corrosive chemicals or vapors in this microwave. This type of microwave is specifically designed to heat, cook or dry foods. It is not designed for laboratory use.
6. As with any appliance, close supervision is necessary when used by children.
7. To reduce the risk of fire in the oven cavity:
 - a. Do NOT overcook food. Carefully attend to the microwave when paper, plastic or other combustible materials are placed inside the microwave to facilitate cooking.
 - b. Remove wire twist ties from paper or plastic bags before placing in microwave.
 - c. If materials inside the microwave should ignite, keep microwave door closed, turn it off, and disconnect the power cord or turn off the power fuse at the circuit breaker panel.
 - d. Do NOT use the microwave cavity for storage purposes.
 - e. Do NOT leave paper products, cooking utensils or food in the cavity when not in use.
8. Do NOT heat oil or fat for deep-frying. It is difficult to control the temperature of oil in the microwave.
9. Pierce foods with heavy skins, such as potatoes, whole squash, apples and chestnuts before cooking.

10. Water, coffee or tea may overheat beyond the boiling point without appearing to be boiling due to surface tension of the liquid. Visible bubbling or boiling when the container is removed from the microwave is not always present.

THIS COULD RESULT IN VERY HOT LIQUIDS SUDDENLY BOILING OVER WHEN A SPOON OR OTHER UTENSIL IS INSERTED INTO THE LIQUID.

- a. Do NOT overheat the liquid
 - b. Stir the liquid both before AND halfway through heating
 - c. Do NOT use straight-sided containers with narrow necks
 - d. After heating, allow the container to stand in the microwave a short time before removing
 - e. Use extreme care when inserting a spoon or other utensil into the container
11. The contents of heating containers should be stirred or shaken and the temperature should be checked before serving to avoid burns.
 12. Cooking utensils may become hot from heat transferred from the heated food. Pot holders may be needed to handle the utensils.
 13. Do NOT cover or block any openings on the microwave.
 14. Do NOT store this microwave outdoors.
 15. Do NOT use this microwave near water (like in a kitchen sink, near a swimming pool, in a wet basement or a similar location).
 16. Do NOT operate this microwave if it has a damaged cord or plug, if it is not working properly, or if it has been damaged or dropped.
 17. Do NOT immerse the cord or plug in water. Keep cord away from heated surfaces. Do NOT let the cord hang over the edge of the table or counter.
 18. Use only thermometers designed for microwaves.
 19. Do NOT operate any heating or cooking appliance beneath the microwave.
 20. Be certain the glass tray and roller rings are in place when the unit is in use.
 21. This appliance should only be serviced by qualified service personnel.

Precautions to avoid exposure to excessive microwave energy:

1. Do NOT attempt to operate this microwave with the door open. Door open operation can result in harmful exposure to microwave energy. It is important not to defeat or tamper with safety interlocks.
2. Do NOT place any objects between the microwave front face and the door, or allow soil or cleaner residue to accumulate on sealing surfaces.
3. Do NOT operate the microwave if damaged. It is particularly important that the microwave door be properly closed and there is no damage to the: (1) door (bent), (2) hinges and latches (broken or loosened), (3) door seals and sealing surfaces.
4. The microwave should NOT be adjusted or repaired by anyone. Contact customer service for replacement or returns.

1. Make sure all packing materials are removed from inside the microwave door.
2. Check the microwave for damage, such as misaligned or bent door, damaged door seals and sealing surface, broken or loose door hinges and latches, and dents inside the cavity or door.
3. This microwave must be placed on a flat, stable surface to hold its weight and the heaviest food likely to be cooked inside.
4. Do NOT place the oven where heat, moisture or high humidity is generated. Do NOT place the microwave near combustible materials.
5. For correct operation, the oven must have sufficient air flow. Allow 8" of space above the microwave, 4" at the back and 2" on each side of the unit.
6. Do NOT cover or block any openings on the microwave. Do NOT remove microwave feet. Do NOT operate the oven without the glass tray, roller support and shaft in their proper positions.
7. Make sure the power supply cord is undamaged and does not run under the microwave or over any hot or sharp surface.
8. The socket must be readily accessible so the microwave can be easily unplugged in an emergency.

Installing the Turntable

- NEVER place the glass tray upside down.
- The glass tray should never be restricted.
- Both the glass tray and turntable ring assembly must always be used during cooking.
- All food and containers of food should always be placed on the glass tray for cooking.

Grounding Instructions

This microwave must be grounded. In the event of an electrical short circuit, grounding reduces risk of electric shock by providing an escape wire for the electric current.

SHORT CORD INSTRUCTIONS

1. A short power supply cord is provided to reduce the risk resulting from becoming entangled in or tripping over a longer cord.
2. Longer detachable power-supply cords or extension cords are available and may be used if care is exercised in their use.
3. If a long detachable power cord or extension cord is used:
 - The marked electrical rating of the detachable power supply cord or extension cord should be at least as great as the electrical rating of the appliance.
 - If the appliance is of the grounded type, the extension cord should be the same type 3-wire.
 - The longer cord should be arranged so that it will not drape over the counter top or tabletop where it can be pulled on by children or tripped over.

Electrical Requirements:

- The electrical requirements for this microwave are 120 volt, 60 Hz, AC only, 20 amp.
- It is recommended that a separate circuit serving only the microwave be provided.
- The microwave is equipped with a 3-prong grounding plug. It must be plugged into a wall outlet properly installed and grounded.

Radio or TV interference:

- Should there be any interference caused by the microwave oven to your radio or TV, check that the microwave oven is on a different circuit, relocate the TV or radio as far away from the oven as feasible or check position and signal of receiving antenna.

Parts & Features

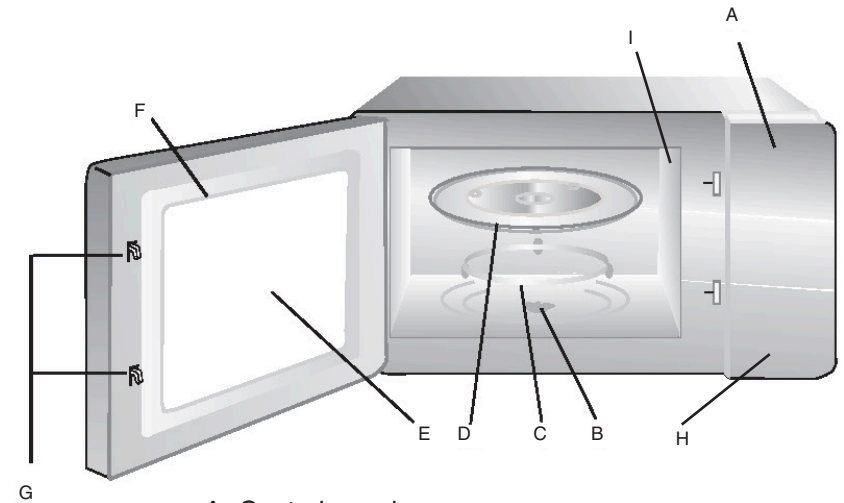

- A. Control panel
- B. Turntable shaft
- C. Turntable ring assembly
- D. Glass Turntable
- E. Oven Window
- F. Door assembly
- G. Door Safety interlock system
- H. Door Release
- I. Wave Guide (Please do not remove the mica plate covering the wave guide)

Turntable Installation



- a. Never place the glass turntable upside down. The glass turntable should never be restricted.
- b. Both glass turntable and turntable ring assembly must always be used during cooking.
- c. All food and containers of food are always placed on the glass turntable for cooking.
- d. If glass turntable or turntable ring assembly cracks or breaks, contact customer service.

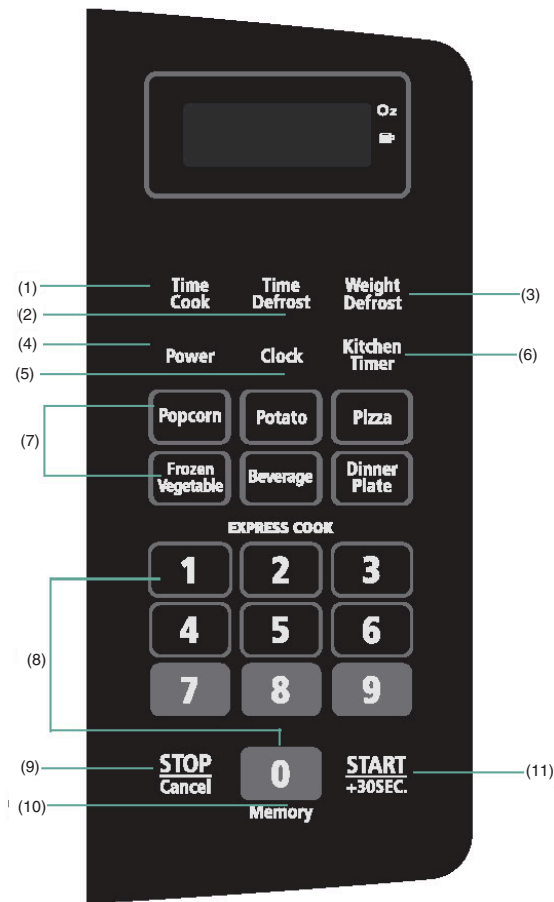

Display Window

Use to indicate clock, cooking time, etc.

1. Time Cook

Allows you to set a specific cooking time.

2. Time Defrost

Allows you to set a specific defrost time.

3. Weight Defrost

Automatically sets the correct power level to defrost food based on weight.

4. Power

Use to set microwave power levels.

5. Clock

Press to set the oven clock.

6. Kitchen Timer

Press to set the timer function

7. Quick Cook Buttons

Instant settings to cook popular foods (popcorn, potato, pizza, frozen vegetable, beverage, dinner plate)

8. Number Pads (0–9)

Use to set clock, cooking time or enter food weight.

9. Stop/Cancel

Press to clear entry before setting a cooking program. Press once to temporarily stop cooking or twice to cancel cooking.

Press and hold to set child lock.

10. Memory Function

Lets you store 3 different cooking programs and reuse them.

11. Start/+30Sec

Press to start cooking program. Press to start cooking quickly and to increase the cooking time.

Each time a button is touched, a beep will sound to acknowledge the touch. When the oven is first plugged in, press STOP/CANCEL to enter into the standby mode.

Setting the clock:

To enter the digital clock time, press the CLOCK button once and then use the NUMBER PADS to set the time of day.

Suppose you want to set the clock to read 6:35:

- Press CLOCK once
- Enter the clock time with the NUMBER PADS (press 6, 3, 5).
- Press CLOCK again to confirm.

NOTE: This is a 12-hour clock. You can see the time during cooking by pressing CLOCK. If you press CLOCK twice, “EE” will be displayed to alert you of an incorrect operation. Press STOP/CANCEL to cancel.

Timer:

The longest time is 99 min. 99 sec.

Suppose you want to set the timer at 30 minutes:

- Press KITCHEN TIMER
- Press the NUMBER PADS to enter “30:00”.
- Press START/+30SEC to confirm.
- When the timer runs out, the buzzer will ring 5 times.

NOTE: You can press STOP/CANCEL once to cancel this function.

NOTE: During kitchen timer, a cooking program cannot be set.

Child Lock:

Use to prevent unsupervised operation of the oven by small children. The CHILD LOCK indicator will show on the display screen and the oven cannot be operated while the CHILD LOCK is set.

- To set the CHILD LOCK: Press and hold the STOP/CANCEL pad for 3 seconds. There will be a long “beep” to confirm that it is locked.
- To cancel the CHILD LOCK: Press and hold the STOP/CANCEL pad for 3 seconds. There will be a long “beep” to confirm that it is unlocked.

Weight Defrost:

- Press WEIGHT DEFROST, the LED will display “DEF1”.
- Press NUMBER PADS to input weight to be defrosted (weight must be entered in ounces in range from 4–100).
- If the weight input is not within 4–100, the input will be invalid. A “beep” will sound and the unit will not work until valid numbers are input.
- Press START/+30SEC to start defrosting and the cooking time remaining will be displayed.

Microwave cooking:

To cook with the microwave, time and power level should be set. The longest cooking time is 99 minutes, 99 seconds. You can adjust the power level by pressing POWER and then using the NUMBER PADS to select the desired power level (as seen in the chart below).

Power Level

Level	100%	90	80	70	60	50	40	30	20	10
NUMBER PAD	1, 0	9	8	7	6	5	4	3	2	1
Display	PL10	PL9	PL8	PL7	PL6	PL5	PL4	PL3	PL2	PL1

To use this feature:

1. Press TIME COOK once, the LED will display "00:00".
2. Press NUMBER PADS to input the cooking time.
3. Press POWER once, the LED will display "PL10" (default power setting is 100%).
Use NUMBER PADS to adjust to the desired power level.
4. Press START/+30SEC to start cooking.

Suppose you want to cook for 5 minutes at 60% microwave power:

- a. Press TIME COOK once.
- b. Press "5", "0", "0" in order.
- c. Press POWER once, then press "6" to select 60% power.
- d. Press START/+30SEC to start cooking.

NOTE: In the process of setting, if the STOP/CANCEL button is pressed or if there is no operation within 1 minute, the oven will go back to the former setting automatically.

NOTE: If "PL0" is selected, the oven will work with the fan for no power.

NOTE: During microwave cooking, POWER can be pressed to change to a different power level. After pressing POWER, the current power level shows in the display for 3 seconds. At this time, you can press NUMBER PAD to change the power level.

Time Defrost:

1. Press TIME DEFROST, the LED will display "DEF2".
2. Press NUMBER PADS input defrosting time. The effective time range is 00:01–99:99.
3. The default microwave power is level 3 "30%" for defrost. If you want to change the power level, press POWER once, the LED will display "PL3" then press the NUMBER PAD to select the corresponding power level.
4. Press START/+30SEC to start defrosting.

Express Cooking:

1. In standby, instant cooking at 100% power level can be started by selecting a cooking time from 1 to 6 minutes by pressing NUMBER PADS 1–6. Press START/+30SEC to increase the cooking time (maximum time is 99 minutes, 99 seconds).
2. In standby, instant cooking at 100% power level with 30 seconds cooking time can be started by pressing START/+30SEC. Each press of this button will increase cooking time by 30 seconds.

NOTE: During cooking and time defrost, time can be added by pressing START/+30SEC.

Multi-stage Cooking:

This microwave can be programmed for up to 2 microwave cooking stages. If one stage is DEFROST, then defrosting will automatically be the first stage. Suppose you want to cook with 90% cooking power for 2 minutes, then 50% power for 1 minute 30 seconds:

- a. Press TIME COOK once, then press "2", "0", "0" in order.
- b. Press POWER once, then press "9" to select 90% cooking power.
- c. Press TIME COOK once, then press "1", "3", "0" in order.
- d. Press POWER once, then press "5" to select 50% power.
- e. Press START/+30SEC to begin cooking.

Menu Cooking:

POPCORN:

1. In standby mode, press POPCORN 1–3 times to select weight.
2. Press START/+30SEC to start cooking.

Press POPCORN	Weight
Once	1.75 oz.
Twice	3.0 oz.
3 times	3.5 oz.

POTATO:

1. In standby mode, press POTATO 1–3 times to select the number of potatoes.
2. Press START/+30SEC to start cooking.

Press POTATO	Number of Potatoes
Once	1
Twice	2
3 times	3

FROZEN VEGETABLE:

1. In standby mode, press FROZEN VEGETABLE 1–3 times to select weight.
2. Press START/+30SEC to start cooking.

Press FROZEN VEGETABLE	Weight
Once	4.0 oz.
Twice	8.0 oz.
3 times	16.0 oz.

BEVERAGE:

1. In standby mode, press BEVERAGE 1–3 times to select capacity.
2. Press START/+30SEC to start cooking.

Press BEVERAGE	Capacity
Once	1 cup (approx. 4 oz.)
Twice	2 cups
3 times	3 cups

DINNER PLATE:

1. In standby mode, press DINNER PLATE 1–3 times to select weight.
2. Press START/+30SEC to start cooking.

Press DINNER PLATE	Weight
Once	9.0 oz.
Twice	12.0 oz.
3 times	18.0 oz.

PIZZA:

1. In standby mode, press PIZZA 1–3 times to select weight.
2. Press START/+30SEC.

Press PIZZA	Weight
Once	4.0 oz.
Twice	8.0 oz.
3 times	14.0 oz.

Inquiring Function:

1. In cooking state, press CLOCK and the LED will display the time for 3 seconds.
2. In cooking state, press POWER to inquire the power level and the current power level will be displayed.

Memory Function:

This setting allows you to store 3 different cooking programs for future use with your microwave.

Suppose you want to set a cooking procedure that is 80% power for 3 minutes and 20 seconds as the second memory (memory 2):

1. Press 0/MEMORY repeatedly until the screen displays “2”.
2. Press TIME COOK once, then press “3”, “2”, “0” in order.
3. Press POWER once, the display will read “PL10”, then press “8” and “PL8” will show on the display.
4. Press START/+30SEC to save the setting. The buzzer will sound once and the procedure will be saved as memory 2. If you press START/+30SEC again, it will start cooking.
5. If the electricity is not cut off, the procedure will be saved all the time. If it is cut off, the procedure will need to be reset.
6. If you want to run a saved procedure, in standby mode press 0/MEMORY (once for memory 1, twice for memory 2, three times for memory 3). The screen will display the memory setting you have selected, then press START/+30SEC to run.

This section lists which utensils can be used in this microwave, which have limited use for short periods, and which should not be used in this microwave.

Recommended:

Microwave Browning Dish—Use to brown the exterior of small items such as steaks, chops or pancakes. Follow the directions provided with your browning dish.

Microwaveable Plastic Wrap—Use to retain steam. Leave a small opening for some steam to escape and avoid placing it directly on the food.

Paper Towels and Napkins—Use for short-term heating and covering; these absorb excess moisture and prevent splattering. Do NOT use recycled paper towel (may contain metal pieces and could ignite).

Glass and Glass-Ceramic bowls and dishes—Use for heating and cooking.

Paper plates and cups—Use for short-term heating at low temperatures. Do NOT use recycled paper (may contain metal and could ignite).

Wax paper—Use as a cover to prevent splattering.

Thermometers—Use only those labeled “Microwave Safe” and follow all directions. Check the food in several places. Conventional thermometers may be used on microwaved food once the food has been removed from the microwave.

Limited Use:

Ceramic, porcelain and stoneware—Use these if they are labeled “Microwave Safe”. If they are not labeled, test them to make sure they can be used safely.

Plastic—Only use if labeled “Microwave Safe”. Other plastics may melt.

Not Recommended:

Glass jars and bottles—Regular glass is too thin to be used in a microwave. It can shatter and cause damage and injury.

Paper bags—These are a fire hazard, except for popcorn bags, which are designed for microwave use.

Styrofoam plates and cups—These can melt and leave unhealthy residue on food.

Plastic storage and food containers—Containers such as margarine tubs can melt in the microwave.

Metal utensils—These can damage your microwave. Remove all metal before cooking.

Wood—Wood will dry out when used in the microwave oven and may split or crack.

NOTE: Should you wish to check if a dish is safe for microwaving, place the empty dish in the microwave and microwave on HIGH for 30 seconds. A dish that becomes very hot should not be used.

Your microwave makes cooking easier than conventional cooking, provided you keep these considerations in mind:

Stirring:

- Stir foods such as casseroles and vegetables while cooking to distribute heat evenly.
- Food at the outside of the dish absorbs more energy and heats quicker, so stir from the outside to the center.
- The microwave will turn off when you open the door to stir your food.

Arrangement:

- Arrange evenly shaped foods, such as chicken pieces or chops, with the thicker, meatier parts toward the outside of the turntable where they receive more microwave energy.

Standing:

- Foods cooking in a microwave build up internal heat and continue to cook for a few minutes after heating stops.
- Let foods stand to complete cooking, especially for foods such as cakes and whole vegetables.
- Roasts need this time to complete cooking in the center without overcooking the outer areas.
- All liquids, such as soup or hot chocolate, should be shaken or stirred when cooking is complete.
- When heating baby food, stir well after removing from microwave and test temperature before serving.

Adding Moisture:

- Microwave energy is attracted to water molecules.
- Food that is uneven in moisture content should be covered or allowed to stand so that the heat disperses evenly.
- Add a small amount of water to dry food to help it cook.

Cleaning and Care

1. Turn off the microwave and unplug the power cord from the wall before cleaning.
2. Keep the inside of the microwave clean. When food splatters or spilled liquids adhere to the microwave walls, wipe with a damp cloth. Mild detergents may be used if the microwave gets very dirty. Avoid using spray or other harsh cleaners. They may stain, streak or dull the door surface.
3. The outside of the microwave should be cleaned with a damp cloth. To prevent damage to the operating parts inside the microwave, water should not be allowed to seep into the ventilation openings.
4. Wipe the window on both sides with a damp cloth to remove any spills or splatters.
5. Do NOT allow the control panel to become wet. Clean with a soft, damp cloth. When cleaning the panel, leave the microwave door open to prevent it from accidentally turning on.
6. If steam accumulates inside or around the outside of the door, wipe with a soft cloth. This may occur when the microwave is operated under high humidity. This is normal.
7. It may be necessary to remove the glass tray for cleaning. Wash the tray in warm, soapy water or in a dishwasher. The roller ring and microwave floor should be cleaned regularly to avoid excessive noise. Wipe the bottom surface of the microwave with a mild detergent.
8. The roller ring may be washed in mild, soapy water or in a dishwasher. When removing the roller ring, be sure to replace it in the proper position.
9. Remove odors from your microwave by combining a cup of water with the juice and skin of one lemon in a microwaveable bowl. Microwave for 5 minutes. Wipe thoroughly and dry with a soft cloth.
10. The microwave should be cleaned regularly and any food deposits should be removed. Failure to maintain the microwave in a clean condition could lead to deterioration of surfaces that could adversely affect the life of the unit and could possibly result in a hazardous situation.
11. Please do not dispose of this appliance in a regular garbage receptacle. Please check to see where you can dispose of such appliances.
12. When it becomes necessary to change the oven light, consult a technician to have it replaced.

Troubleshooting

Check your problem by using the chart below and try the solutions for each problem. If the microwave oven still does not work properly, contact a qualified service technician for service.

TROUBLE	POSSIBLE CAUSE	POSSIBLE REMEDY
Oven will not start	a. Electrical cord for oven is not plugged in b. Door is open c. Wrong operation is set	a. Plug into the outlet b. Close the door and try again c. Check instructions
Arcing or sparking	a. Materials to be avoided in the oven were used b. The oven is operated while empty c. Spilled food remains in the cavity	a. Use microwave-safe cookware only b. Do not operate with the oven empty c. Clean cavity with a damp towel
Unevenly cooked foods	a. Materials to be avoided in the microwave oven were used b. Food is not defrosted completely c. Cooking time, power level is not suitable d. Food is not turned or stirred	a. Use microwave-safe cookware only b. Completely defrost food c. Use correct cooking time, power level d. Turn or stir food
Overcooked foods	Cooking time, power level is not suitable	Use correct cooking time, power level
Undercooked foods	a. Materials to be avoided in the microwave oven were used b. Food is not defrosted completely c. Oven ventilation ports are restricted d. Cooking time, power level is not suitable	a. Use microwave-safe cookware only b. Completely defrost food c. Check to see that oven ventilation ports are not restricted d. Use correct cooking time, power level
Improper defrosting	a. Materials to be avoided in microwave oven were used b. Cooking time, power level is not suitable c. Food is not turned or stirred	a. Use microwave-safe cookware only b. Use correct cooking time, power level c. Turn or stir food

If any item, for any reason, does not meet your expectations, just return it to us.

We'll gladly either:

- Refund your merchandise amount
- Credit your account
- Send a replacement

You can return any unused item in its original packaging within 60 days of its receipt for a full refund of the purchase price (excluding shipping and handling charges).

Please send returns to:

**Montgomery Ward, Inc.
Attn: Customer Returns
2000 Harrison Suite 100
Clinton, IA 52732-6676**

When returning an item:

- Use the original packaging and pack it securely.
- Please adequately insure your item in case you need to make a claim with the carrier you choose for returning your item.
- Include your order number and reason for return.
- We recommend keeping the receipt for 4 weeks.

Montgomery Ward®

Improving American Homes Since 1872

1 Year Limited Warranty

Montgomery Ward, Inc. warrants this product to be free from defects in material and workmanship for one year from provable date of purchase.

Within this warranty period, Montgomery Ward will repair or replace, at its option, defective parts of this product at no charge, provided the product is returned, freight prepaid with proof of purchase to Montgomery Ward. Allow 2-4 weeks for return shipping.

This warranty does not cover improper installation, misuse, abuse or neglect on part of the owner. Warranty is also invalid in any case that the product is taken apart or serviced by an unauthorized service station.

This warranty gives you specific legal rights and they may vary from state to state.

THE FOREGOING WARRANTIES ARE IN LIEU OF ALL OTHER WARRANTIES AND CONDITIONS, EXPRESS OR IMPLIED, INCLUDING BUT NOT LIMITED TO THOSE OF MERCHANTABILITY OR FITNESS FOR A PARTICULAR PURPOSE.

Montgomery Ward Customer Service
8:00 am to Midnight CST, Monday through Friday

Wards.com 1-888-557-3848