



# Electric Pasta Maker Instruction Manual

MODEL: MD150-1



*“Life is happening...  
we’ll help you live it, one moment at a time.”*



President, Ginny’s

Thank you for purchasing a Ginny’s Brand Pasta Maker. You’ve just brought more fun and function into your kitchen! You’ll be amazed at what you can make! With its 3 rolling heads, you’ll be turning out delicious fettuccini, spaghetti—and sheets of pasta for raviolis, lasagna and more! Its nice, heavy weight means you won’t have to fuss with clamps or an unstable machine. And with a low- or high-speed electrical switch, you won’t have to master cranking with 1 hand while feeding raw dough through with the other. Enjoy!

## TABLE OF CONTENTS

|                                  |      |
|----------------------------------|------|
| Important Safeguards.....        | 3    |
| Polarized Plug .....             | 4    |
| Specifications.....              | 4    |
| Part Names.....                  | 5    |
| How to Operate .....             | 6    |
| Cleaning & Care.....             | 7    |
| Operating Guidelines & Tips..... | 7-8  |
| Recipes.....                     | 9-10 |
| Warranty .....                   | 11   |

## SAVE THESE INSTRUCTIONS

### READ ALL SAFETY INSTRUCTIONS BEFORE USING THIS APPLIANCE

When using electrical appliances, basic safety precautions should always be followed, including the following:

1. Read all instructions carefully before use.
2. Before using this appliance, make sure that the voltage of the power outlet corresponds with the voltage on the rating plate of the appliance.
3. Always remove the plug from the electrical outlet when the appliance is not in use.
4. Do NOT immerse in water for cleaning.
5. NEVER leave the appliance unattended when it is switched on.
6. This appliance is not a toy and must not be used by children. Keep hands and fingers away from the rollers.
7. Do NOT insert utensils or cloths between the rollers.
8. When working with the motorized rollers, do NOT wear ties, scarves or long chains and keep hair tied back.
9. This appliance is intended for household use only.
10. Do NOT unplug by pulling on the power cord. Always unplug by pulling the plug.
11. Do NOT turn the appliance on if it appears faulty in any way.
12. This appliance is not intended for use by persons (including children) with reduced physical, sensory or mental capabilities or lack of experience or knowledge unless they have been given supervision or instruction concerning the use of the appliance by a person responsible for their safety.
13. Children should be supervised to ensure that they do not play with the appliance.
14. Do NOT use this appliance if the power cord is damaged in any way. Contact Ginny’s toll-free Customer Service for information on replacement or returns.

# POLARIZED PLUG

## SHORT CORD INSTRUCTIONS

1. A short power supply cord is provided to reduce the risk resulting from becoming entangled in or tripping over a longer cord.
2. Longer detachable power-supply cords or extension cords are available and may be used if care is exercised in their use.
3. If a long detachable power cord or extension cord is used:
  - The marked electrical rating of the detachable power supply cord or extension cord should be at least as great as the electrical rating of the appliance.
  - If the appliance is of the grounded type, the extension cord should be the same type 3-wire.
  - The longer cord should be arranged so that it will not drape over the countertop or tabletop where it can be pulled on by children or tripped over.

# PART NAMES

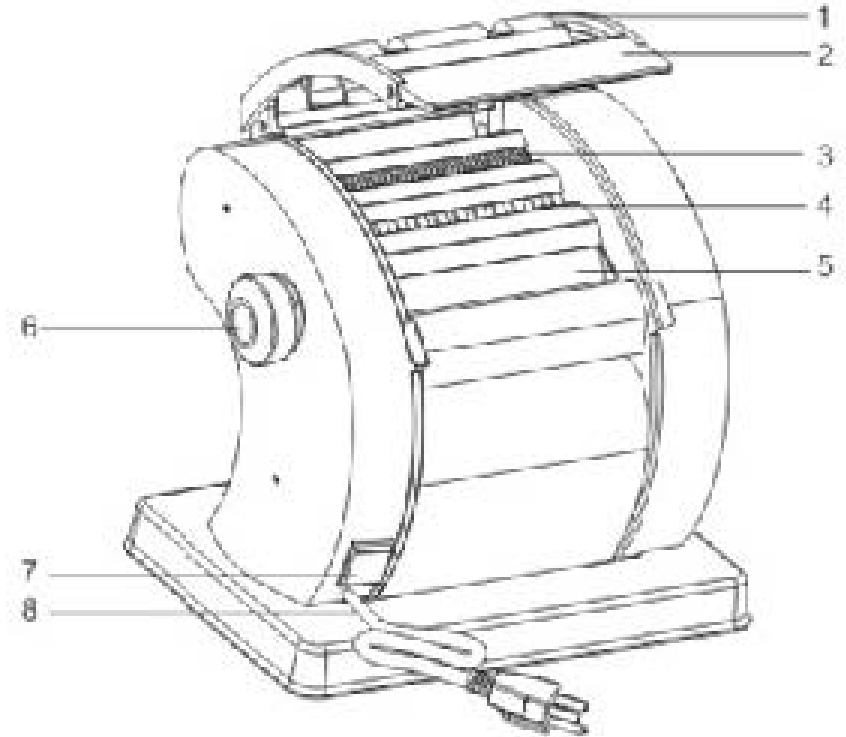

# SPECIFICATIONS

|                     |                              |
|---------------------|------------------------------|
| Power Consumption:  | 120V/60Hz, 90W               |
| Outside Dimensions: | 11.25" L x 7.5" W x 11.25" H |

1. Plastic Safety Covers for Rollers
2. Cover with Auto Shut-Off
3. Spaghetti Cutter
4. Fettucini Cutter
5. Flat Roller
6. Flat Roller Thickness Dial
7. On/Off Switch
8. Power Cord

# HOW TO OPERATE

## Before Using for the First Time:

Remove all packaging materials. Clean the Pasta Maker with a dry cloth to remove excess oil. The spaghetti and fettucini cutters may require you to feed some pasta dough through them to remove all of the oil. This “dirty” pasta should be discarded and NOT consumed.

1. Make your pasta dough by following a favorite recipe (or trying ours, found on page 9).
2. Plug the power cord into an electrical outlet.
3. Adjust the roller to the widest setting (1 is the widest; 9 is the narrowest). To adjust the width, pull Flat Roller Thickness Dial (6) out and turn to the desired setting. The knob will click and lock into place.
4. The motor has 2 speed settings: Low and High
5. When switched ON, the Flat Roller (5) and both cutters will operate at the same time. The Plastic Safety Covers (1) are designed to cover the rollers that aren't being used at the time. Slide the 2 Plastic Safety Covers (1) over the Spaghetti (3) and Fettucini (4) cutters.
6. Feed the dough through the roller. Once the dough has passed through, adjust the roller to the next narrowest setting and feed the dough through again. Repeat this process until the desired pasta thickness has been reached.
7. When you are ready to use either the Fettucini (4) or Spaghetti Cutter (3), slide the corresponding Plastic Safety Cover (1) over the roller and the cutter not being used and pass the flat pasta through the cutter.

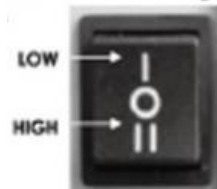

- When feeding dough through the roller, adjust the Flat Roller Thickness Dial (6) from the widest setting to the narrowest.
- After adjusting the width of the roller, turn on at your preferred speed. When you first use the Pasta Maker, we recommend beginning with “LOW”.

**IMPORTANT:** When you want to adjust the thickness of the rollers, ALWAYS switch the Pasta Maker to off “O” first. Do NOT adjust the width of the rollers while the Pasta Maker is running as this will damage the gear system.

- Do NOT run the Pasta Maker continuously for longer than 15 minutes in order to protect the motor. After 15 minutes of continuous use, we advise to turning the Pasta Maker off “O” and allowing it to rest for 15 minutes before using again.

# CLEANING & CARE

**Do NOT use harsh or abrasive cleaners**

**Do NOT immerse in water or place in a dishwasher**

It is important that the rollers remain dry so that they do not clog with flour or so that they will not rust.

1. To clean the Pasta Maker, first remove the plug from the electrical outlet.
2. Remove excess dough from the rollers. If you have a small piece of dough leftover, pass it through the rollers so that any excess dough sticks to it.
3. Wipe the rollers with a dry cloth or a brush. Dry thoroughly before reusing.
4. To clean the exterior of the maker, wipe the outside surface with a damp cloth and polish dry. Do NOT use harsh or abrasive cleaners as they may scratch the body of the maker.

**WARNING:** Do NOT submerge the Pasta Maker, power cord or plug in water or any other liquid. Do NOT wash in a dishwasher.

## OPERATING GUIDELINES & TIPS

- Making perfect pasta is an art that will take time to perfect. Do not expect perfect results the first time, with practice you should get there.

### Hints for Mixing Dough:

- Mix all of the dry ingredients together and pour into a heap. Make a well in the center with your fingers.
- Mix all of the wet ingredients together in a bowl, then pour into the well of dry ingredients.
- Using a fork, gradually combine the dry ingredients from inside the well with the wet ingredients until the wet ingredients are no longer runny. Be careful not to break the wall of dry ingredients or the wet mixture will escape.
- Quickly use both hands to mix in the remaining dry ingredients over the wet mixture so that it is completely covered.
- Begin working the dough with your hands until all of the dry ingredient mixture is combined with the wet mixture. The dough should feel moist but not sticky. If it is sticky, slowly add more flour until you have the right consistency.
- Continue kneading the dough until it is uniform and smooth.
- Cover the dough and allow it to rest for 20–30 minutes.

# OPERATING GUIDELINES & TIPS

## Hints for Rolling Dough:

It is preferable to roll the dough before putting it through the Pasta Maker. This allows the dough to be stretched rather than compressed through the rollers of the Pasta Maker. It will also create more absorbent pasta.

- Uncover the dough and knead again for about a minute so that the moisture that has collected on the surface is worked back into the dough.
- Flatten the dough a little bit with your hands to form a round disk and place it on your work surface.
- Roll the dough out until it is approximately 1/4" thick. You may need to fold the pasta 5–10 times, adding flour in the middle. This is a very important key to creating perfect pasta.
- Cut the dough into pieces that will fit through the width of the Pasta Maker (5 1/2"). With the rollers at the widest setting, feed the dough through. Hold the dough as it comes through, but do NOT pull or stretch the dough.
- Once all of the dough has been fed through the Pasta Maker one time, reduce the width of the rollers by 1 notch and run the dough pieces through the Pasta Maker again.
- Continue to reduce the width of the rollers 1 notch at a time. Run all of the pieces through the Pasta Maker until you have reached the narrowest roller setting. Lay the pieces out on a dry tea towel or table cloth.

For lasagna sheets, cut the rolled dough into 8" strips (use a knife or pair of scissors).

For fettucini or spaghetti, cut the rolled pieces to 12" lengths (with a knife or pair of scissors) and pass them through the cutters.

**NOTE:** If the cutters will not cut, this means the dough is too soft. If this happens, you should pass the dough through the smooth rollers after adding some flour to the mixture.  
If the dough is too dry and cannot be cut by the rollers, add a little water to the mixture and pass through the smooth rollers.

**Allow pasta to dry for at least 1 hour before cooking.**

# RECIPES

## Basic Pasta Dough

### INGREDIENTS:

1 cup all-purpose flour  
1 tsp. salt  
2 large eggs

2/3 cup fine Semolina flour  
1 Tbsp. olive oil  
1 Tbsp. hot water

### Directions:

1. Mix the eggs, water and oil in a bowl with a whisk until well blended.
2. In a separate bowl, mix the flour, Semolina flour and salt.
3. Combine the wet and dry ingredients (we recommend using the hints on page 7 of this manual).
4. Follow the instructions and hints on the previous page to roll the dough to the desired thickness with the Pasta Maker.

### Variations:

#### Red Pasta Dough

1. To make red pasta, add 1 level tablespoon of tomato paste for each egg used.

#### Green Pasta Dough

1. Green pasta is made by removing the stems of fresh spinach and washing and steaming it.
2. Chop very finely and squeeze out as much water as possible.
3. Add the finely chopped spinach to the egg/oil mixture and mix until well blended. Finish the dough as described above.

#### Lemon Flavored Pasta Dough:

1. Add 1 tablespoon of lemon-infused olive oil plus the zest of 1 lemon to the egg/oil mixture.

## Cheese Sauce

### INGREDIENTS:

2 Tbsp. butter  
1 1/4 cup milk, heated  
2 Tbsp. white wine vinegar  
3 Tbsp. heavy cream  
1/2 cup parmesan cheese, grated  
2 Tbsp. sour cream

1 Tbsp. all-purpose flour  
1/8 tsp. nutmeg  
1/4 tsp. thyme leaves  
1/2 cup mozzarella cheese, grated  
1 Tbsp. mustard powder

### Directions:

1. Melt butter in a large saucepan, over medium heat and stir in flour and cook until the roux is slightly colored. (Do not allow to darken too much.)
2. Stir in the heated milk, stirring constantly and cook for 15 minutes until mixture thickens and is smooth.
3. Add the freshly grated nutmeg, vinegar and crumbled thyme and season to taste.
4. Stir in the heavy cream and combine thoroughly.
5. Stir in the grated cheeses, mustard and sour cream and stir until the cheeses have melted and the sauce is blended.

# RECIPES

## Basic Marinara Sauce

### INGREDIENTS:

- |  |                                |
|--|--------------------------------|
| 2 Tbsp. olive oil  | 1/2 cup onion, chopped         |
| 1 clove garlic, finely chopped                           | 2 Tbsp. fresh parsley, chopped |
| 1-14.5 oz. can Italian plum tomatoes, chopped with juice | 2 bay leaves                   |
| 2 Tbsp. tomato purée                                     | 1 tsp. dried oregano           |
| Salt & pepper to taste                                   | 1 Tbsp. sugar                  |

### Directions

1. Heat olive oil in a large saucepan over medium heat and sauté onions for 2–3 minutes until tender.
2. Add the garlic and sauté for another minute.
3. Stir in the chopped tomatoes, parsley, oregano, bay leaves, tomato puree and sugar. Add salt and pepper to taste.
4. Heat until mixture comes to a boil, reduce heat and simmer, uncovered for 15–20 minutes, stirring occasionally.
5. Adjust the seasoning and discard the bay leaves.

NOTE: Top with freshly grated parmesan cheese.

## Bechamel (White) Sauce

### INGREDIENTS:

- |                             |                                 |
|-----------------------------|---------------------------------|
| 1 3/4 cup milk              | 2 bay leaves                    |
| 3 whole cloves              | 1 small onion                   |
| 1/4 cup butter              | 6 Tbsp. all-purpose flour       |
| 1 1/2 cup half & half cream | 1/8 tsp. nutmeg, freshly grated |
| Salt & pepper to taste      |                                 |

### Directions:

1. Pour milk into a small saucepan with the bay leaves. Stud the onion with cloves and add to the milk. Bring to a boil.
2. Remove from heat and allow to cool.
3. Strain the milk mixture into a clean bowl and discard the onion and cloves.
4. Melt the butter in a saucepan over medium heat and stir in the flour to make a roux and heat through. (Do not allow to darken too much.)
5. Slowly pour in the milk, stirring constantly. Cook for approximately 3 minutes, then add the half & half.
6. Bring mixture to a boil, then remove from heat and add nutmeg and season with salt and pepper.

NOTE: You may add 1 cup of drained, sliced mushrooms or 1/2 cup chopped parsley.

# WARRANTY

Ginny's warrants this product free from defects in material and workmanship for one year from provable date of purchase.

Within this warranty period, Ginny's will repair or replace, at its option, defective parts at no charge, provided the product is returned, freight prepaid with proof of purchase to Ginny's.

Allow 2-4 weeks for return shipping.

This warranty does not cover improper installation, misuse, abuse or neglect on part of the owner.

Warranty is also invalid in any case that the product is taken apart or serviced by an unauthorized service station.

This warranty gives you specific legal rights and they may vary from state to state.

THE FOREGOING WARRANTIES ARE IN LIEU OF ALL OTHER WARRANTIES AND CONDITIONS, EXPRESS OR IMPLIED, INCLUDING BUT NOT LIMITED TO THOSE OF MERCHANTABILITY OR FITNESS FOR A PARTICULAR PURPOSE.

### Customer Service

Phone: 1•800•544•1590

8:00 am to Midnight, Monday through Friday

