

Montgomery Ward®

Montgomery Ward®

Perfect
for the
man cave or
workshop

Toolbox Fridge



MODEL: SC50C-2

Montgomery Ward Customer Service
1112 7th Avenue, Monroe, WI 53566
8:00 am to Midnight, Monday through Friday

Wards.com 1-888-557-3848

Instruction Manual

Item No.: 718977
120V~, 60Hz, 76W

Wards.com 1-888-557-3848



Thank you for purchasing your Toolbox Fridge by Montgomery Ward®. We guarantee that it will perform to the highest standard, time after time, with all the convenience, easy cleanup and durability you rely on from Wards.

Your new Toolbox Fridge will fit right in with the décor of any garage, workshop or man cave. With the small footprint it won't take up much space, but it's still large enough take care of your beverages and snacks.

Table of Contents

Important Safeguards.....	3
Parts & Features.....	4
Installation	5
Use and Care Instructions	5
Troubleshooting.....	6
Energy-Saving Tips	7
Warranty & Return Information.....	8-9



3102543
Conforms to UL Std. 471
Certified to CSA Std. C22.2 No. 120-13

PLEASE SAVE THESE INSTRUCTIONS

THIS APPLIANCE IS FOR INDOOR USE ONLY

© 2015 Montgomery Ward, Inc. All rights reserved.

Important Safeguards

PLEASE READ THESE INSTRUCTIONS BEFORE USE

Basic safety precautions should always be followed when using the Toolbox Fridge.

WARNING: Before discarding this appliance, remove the door and leave shelves in place to avoid child entrapment.

WARNING: TO AVOID THE RISK OF ELECTRICAL SHOCK, ALWAYS MAKE SURE THE PRODUCT IS UNPLUGGED FROM THE ELECTRICAL OUTLET BEFORE ASSEMBLING, DISASSEMBLING OR RELOCATING. DO NOT TRY TO SERVICE THIS PRODUCT YOURSELF.

- To protect against electrical shock, do not place cord, plug or appliance in water or other liquid.
- Close supervision is necessary when any appliance is used by or near children. Do not allow children to climb inside of appliance.
- Unplug from outlet when not in use and before moving. Always unplug using the plug and not by pulling on the cord.
- Do not operate any appliance with a damaged cord or plug, or after the appliance malfunctions or has been damaged in any manner. Call our toll-free customer service number for information regarding returning or replacing the product.
- Maintain a ventilation clearance of at least 2 inches around all sides of appliance.
- Do not use outdoors.
- Do not use appliance for anything other than its intended use.
- Only position on a solid level surface.
- Do not allow unit to rest on power cord.
- Never carry, push or pull the appliance by the door.
- Do not move or tilt while in operation.
- Never install the unit where it could be subjected to:
 - Other products that produce heat (furnace, stove, dishwashers, etc.).
 - Flammable materials, including liquids.
 - Excessive dust.
 - Mechanical vibration or shock.
 - Moisture.
- Never store paint, gasoline, oil or other flammable liquids in fridge.

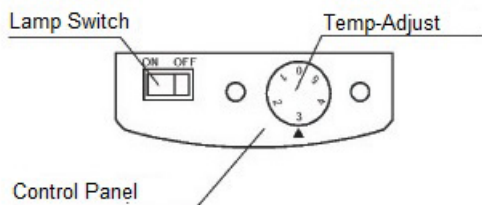
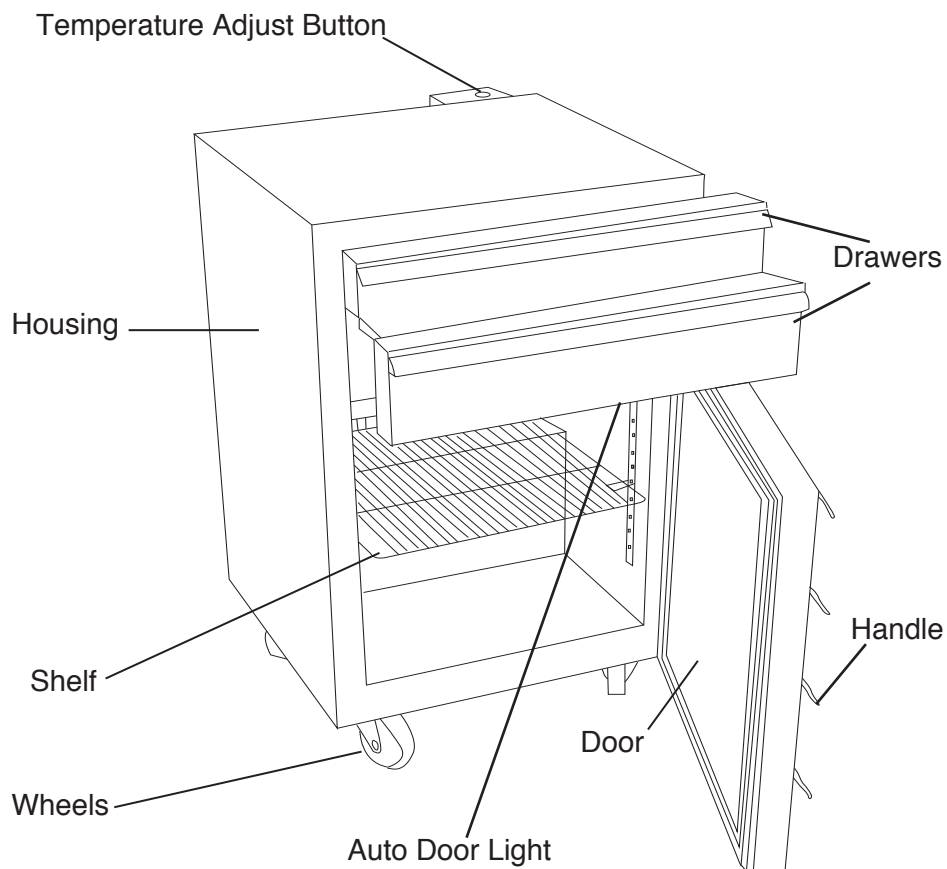

1. After unpacking, dispose of all packing materials in accordance with local ordinances.
2. Position the refrigerator on a solid, level surface. Lock the wheels to secure in place.
3. Refrigerator should have a minimum of 2 inches of clearance around the entire unit to allow for adequate ventilation.
4. Allow the unit to sit upright and undisturbed for 30 minutes before plugging in.
5. After the unit has settled for 30 minutes, plug the unit into an outlet that is approved for the voltage listed on the rating plate.
6. Turn the temperature control knob to the desired temperature, with 1 being cool and 5 being the coldest. Factory default is 3.

Use and Care Instructions

Now that your Toolbox Fridge is set up and ready to use, there are a few basic things to keep in mind:

- Allow 1/2 inch of space between the items in the fridge and the interior walls. This will keep the air circulating properly and prevent the condenser from operating unnecessarily.
- Condensation can form on the inside of the door when the humidity is above 65%. This is normal. Keep door closed and the seal clean.
- The condenser coils are located inside the walls of the appliance, which can cause the walls to become warm. Avoid putting heat sensitive items next to unit.
- When refrigerant passes through the condenser coils, it can cause a bubbling sound.

To keep your appliance looking good and in proper working order, follow these cleaning instructions:

- Clean interior and exterior with soapy water and a soft cloth. Never use an abrasive cleanser or pad as this could damage the finish.
- Vacuum or brush the condenser unit on the back of the appliance to avoid dust buildup.
- Clean the door with a soft, damp cloth.

Troubleshooting

Problem	Possible Cause	Remedy
Unit makes a bubbling sound.	Refrigerant is passing through the condenser coils.	This is normal operation. Adjust temperature control.
Unit makes a clunking sound.	The unit is not level.	Move fridge to a level surface.
Fan sounds loud.	Dust may have accumulated.	Vacuum or brush the dust off of the condenser unit on the back of the fridge.
Items in fridge are not cold.	Thermostat is set at too low of a temperature.	Adjust the temperature to a higher setting.
	Proper amount of airflow is not maintained.	Allow 1/2 inch of space between items and inside walls.
	Door is not fully sealed.	Make sure door is shut properly and that seal is tight and clean.
Items in fridge are freezing.	Thermostat is set at too high of a temperature.	Adjust the temperature to a lower setting.
Ice buildup on interior walls.	Thermostat may be faulty.	If lowering the temperature does not fix the problem, call for service.

Energy-Saving Tips

- Install the appliance in a cool, well-ventilated room and make sure that the air openings of the cabinet are not obstructed.
- Always allow food to cool down to room temperature before placing it in the refrigerator.
- Try to avoid keeping the door open for long periods or opening the door too frequently as warm air will enter the cabinet, lower the efficiency of the refrigerator and increase the work of the compressor.
- Ensure there are no obstructions preventing the door from closing properly.
- Ensure food items are packaged in airtight containers.
- Do not overstock refrigerator.

If any item, for any reason, does not meet your expectations, just return it to us. We'll gladly either:

- Refund your merchandise amount
- Credit your account
- Send a replacement

You can return any unused item in its original packaging within 60 days of its receipt for a full refund of the purchase price (excluding shipping and handling charges).

Please send returns to:

**Montgomery Ward, Inc.
Attn: Customer Returns
2000 Harrison Suite 100
Clinton, IA 52732-6676**

When returning an item:

- Use the original packaging and pack it securely.
- Please adequately insure your item in case you need to make a claim with the carrier you choose for returning your item.
- Include your order number and reason for return.
- We recommend keeping the receipt for 4 weeks.



1 Year Limited Warranty

Montgomery Ward, Inc. warrants this product to be free from defects in material and workmanship for one year from provable date of purchase.

Within this warranty period, Montgomery Ward will repair or replace, at its option, defective parts of this product at no charge, provided the product is returned, freight prepaid with proof of purchase to Montgomery Ward. Allow 2-4 weeks for return shipping.

This warranty does not cover improper installation, misuse, abuse or neglect on part of the owner. Warranty is also invalid in any case that the product is taken apart or serviced by an unauthorized service station.

This warranty gives you specific legal rights and they may vary from state to state.

THE FOREGOING WARRANTIES ARE IN LIEU OF ALL OTHER WARRANTIES AND CONDITIONS, EXPRESS OR IMPLIED, INCLUDING BUT NOT LIMITED TO THOSE OF MERCHANTABILITY OR FITNESS FOR A PARTICULAR PURPOSE.

Montgomery Ward Customer Service
8:00 am to Midnight CST, Monday through Friday

Wards.com 1-888-557-3848