



## 10-IN-1 EVERYTHING OVEN User Guide

Item: 735660

*Recipes  
Inside!*



***Ginnys.com • 800-544-1590***

** *Facebook.com/GinnysBrand***

** *Pinterest.com/GinnysBrand***

** *Ginnys.com/Blog***

*“Life is happening.*

*We’ll help you live it...one moment at a time.”*

---

---



Thank you for purchasing a Ginny’s Brand 10-in-1 Everything Oven. Grill, saute, fry, steam, broil, bake, roast, toast, warm, and cook on a rotisserie spit (three different ways) - using just one compact counter-top unit! And with fun color choices, you’ve just added another style element to your kitchen too. Enjoy!

*Ginny*  
President, Ginny’s

---

---

## **TABLE OF CONTENTS**

Important Safeguards	3
Electrical Safety and Specifications	4
Get to Know Your Oven	4-6
How to Operate	6-14
Cleaning & Care	15
Recipes	15-19
Warranty	20

# IMPORTANT SAFEGUARDS

## **READ CAREFULLY BEFORE USING AND SAVE THESE INSTRUCTIONS!**

- FOR HOUSEHOLD USE ONLY. Do not use this appliance for other than its intended use.
- REMOVE all packaging materials and labels before first use. BE CAREFUL TO NOT DISCARD ANY SMALL PIECES. SOME OF THEM ARE NESTED TIGHTLY IN PACKAGING MATERIAL.
- WASH all removable parts before first use. See Cleaning & Care.
- A SHORT CORD is provided to reduce the hazards resulting from entanglement or tripping. Do not drape the cord over the counter or tabletop, where it can be pulled on or tripped over. Never wrap the cord tightly around the appliance, as this could cause the cord to fray or break.
- We do not recommend using an extension cord with this appliance. However, IF AN EXTENSION CORD IS USED, the marked electrical rating should be at least as great as the electrical rating of this appliance.
- CLOSE SUPERVISION is necessary when using this appliance near CHILDREN.
- A fire may occur if this appliance is used near FLAMMABLE MATERIALS, including curtains, towels, walls, etc. Do not place any paper, plastic, or other non-food items in the appliance. Do not place the appliance or its cord on or near a heated surface, or in a heated oven.
- This appliance should always be used on a STABLE, DRY, HEAT-RESISTANT SURFACE. Do not use near water.
- Do not use an accessory or attachment not recommended by Ginny's, as this may cause injury, or damage the appliance.
- Keep hands, hair and clothing away from all MOVING PARTS.
- Always use OVEN MITTS when handling hot food or appliances. Do not attempt to move an appliance when it is hot or has hot contents.
- Do not use outdoors.
- Turn OFF AND UNPLUG this appliance when not in use.
- NO SERVICEABLE PARTS INSIDE THIS APPLIANCE.
- DO NOT USE AN APPLIANCE WITH A DAMAGED CORD OR PLUG, OR AFTER THE APPLIANCE MALFUNCTIONS, OR HAS BEEN DAMAGED IN ANY MANNER.

# ELECTRICAL SAFETY

This appliance is equipped with a polarized plug in which one prong is wider than the other. This is a safety feature to reduce the risk of electrical shock. The plug should be attached to the appliance before connecting to an electrical outlet. The plug will fit into a polarized outlet only one way. If you are unable to insert the plug into the outlet, try reversing the plug. If it still does not fit, contact a qualified electrician. Do not attempt to modify the plug in any way. Ginny's cannot accept any liability for damage or injury resulting from failure to observe these safety procedures.

## SPECIFICATIONS

POWER RATING	120 V, 60 Hz, 1450 W
CORD LENGTH	36"
DIMENSIONS	19.75" L x 16" D x 15" H
MODEL	TU-1028RF

## GET TO KNOW YOUR OVEN

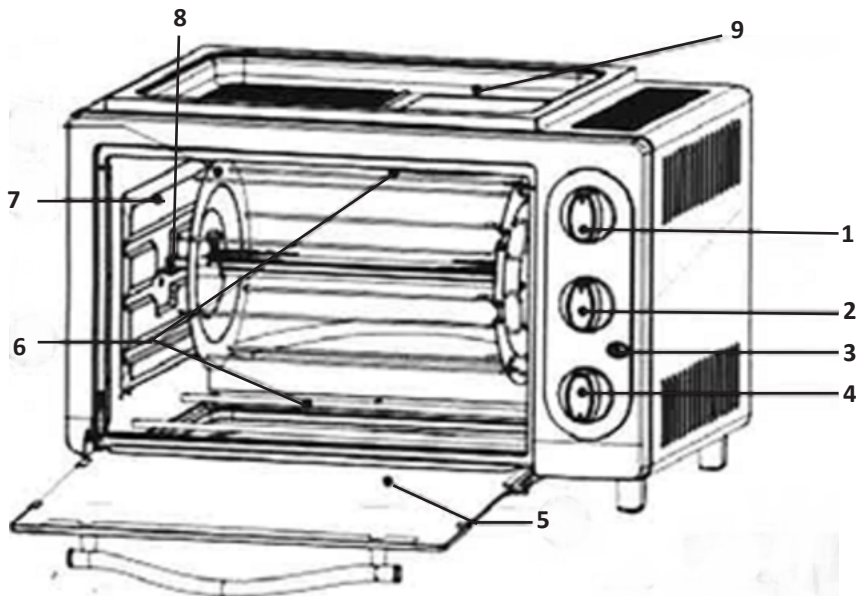

# GET TO KNOW YOUR OVEN

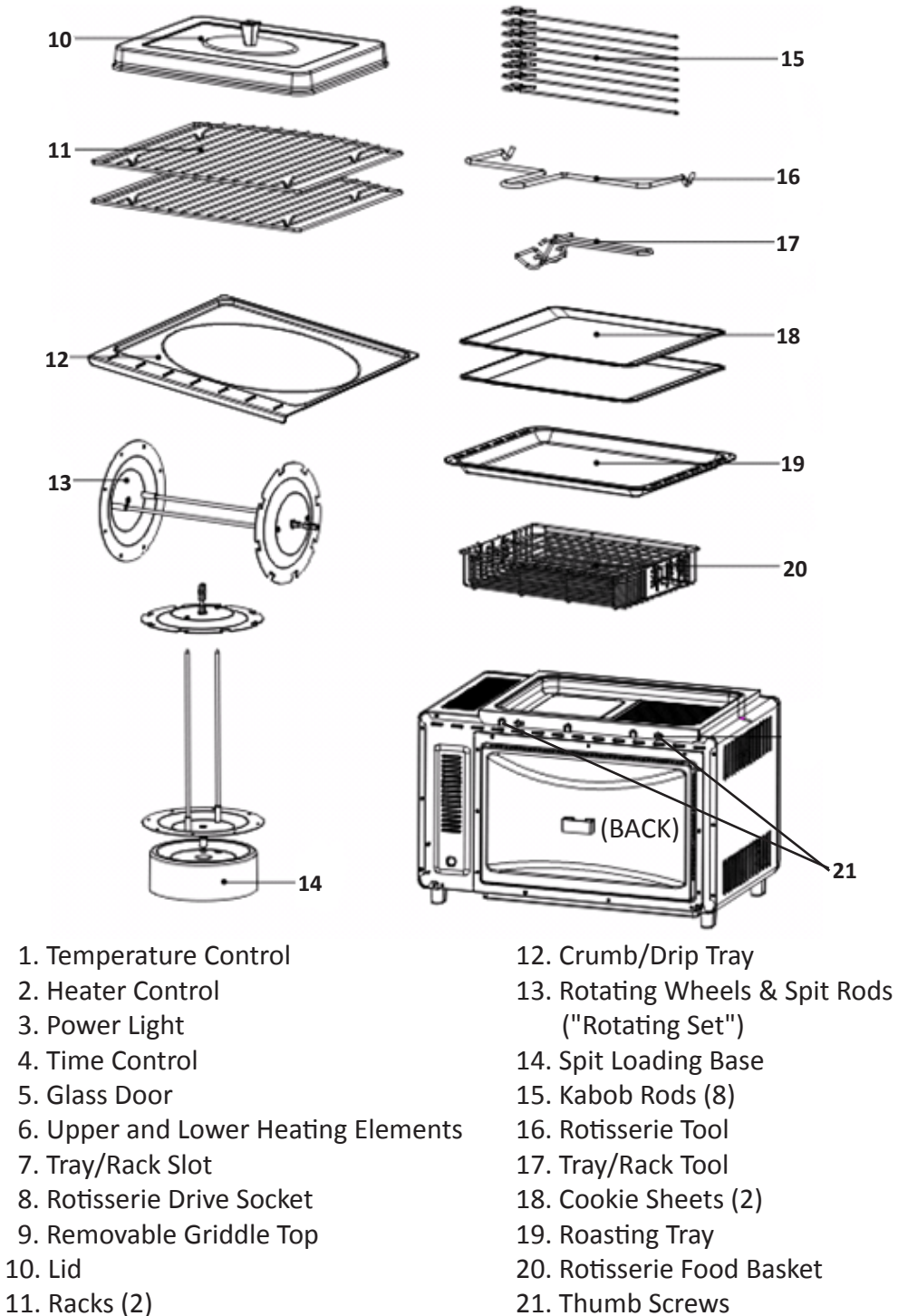

- 1. Temperature Control
- 2. Heater Control
- 3. Power Light
- 4. Time Control
- 5. Glass Door
- 6. Upper and Lower Heating Elements
- 7. Tray/Rack Slot
- 8. Rotisserie Drive Socket
- 9. Removable Griddle Top
- 10. Lid
- 11. Racks (2)

- 12. Crumb/Drip Tray
- 13. Rotating Wheels & Spit Rods ("Rotating Set")
- 14. Spit Loading Base
- 15. Kabob Rods (8)
- 16. Rotisserie Tool
- 17. Tray/Rack Tool
- 18. Cookie Sheets (2)
- 19. Roasting Tray
- 20. Rotisserie Food Basket
- 21. Thumb Screws

# GET TO KNOW YOUR OVEN

## CONTROLS

**Temperature Control:** Turn to set oven temperature up to 450°F.

**Heater Control:** Choose elements - UPPER, ALL/ROTISSERIE or LOWER.

**Time Control:** 60 minute timer with bell alert, or STAY ON.

## ASSEMBLY

After cleaning all parts (see Cleaning & Care on page 15), assemble your oven:

1. Insert the crumb/drip tray into the slot under the glass door (you may have to wiggle it, as it's a snug fit).
2. Attach the griddle top by slipping the slots over the thumb screws on the back of the oven, set the top down, and turn the screws to the vertical position to secure.
3. Place the lid on top of the griddle.
4. Insert the racks on to the tray/rack slots in the oven.
5. Rotisserie accessories assembly instructions are on pages 7 and 8.

**Note:** Due to the manufacturing process, smoke and odor may be emitted during the first use. This is normal and causes no harm. We recommend you pre-heat the oven on ALL/ROTISSERIE, at 375-400°F, approximately 30 minutes to eliminate smoke and odor before cooking for the first time.

## HOW TO OPERATE

**Tip:** The oven has been designed to utilize everyday recipes. However, cooking temperatures and times may vary. We recommend you monitor the cooking progress by checking your food frequently during operation to ensure the best results.

**WARNING:** When in use, keep oven sides and top a minimum of 10-12 inches away from walls and cupboards. Oven will be hot - use handles and wear oven mitts.

# HOW TO OPERATE

## ROTISSERIE

**Tip:** We recommend using cotton butcher's twine to bind foods when using the rotisserie. This helps keep food from touching heating elements.

1. Plug in the oven. Set temperature to 450°F and set the heater to ALL/ ROTISSERIE.
2. Remove racks.
3. Turn the time to 10 - 15 minutes to preheat the oven.
4. Place the rotating wheel with the pointed end (and slots on the edge) onto the spit loading base. Screw the two spit rods onto the rotating wheel on the base. (The base will hold the wheel and spit rods upright while you load the food onto the spit rods.)
5. Load the food on the spit rods ensuring the food is *centered*. **We recommend a maximum weight of 7 pounds.**
6. Align and set the other rotating wheel (with holes around the edge) onto the spit rods. Carefully remove the rotating set from the loading base.
7. Using the rotisserie tool, mount the rotating set in the oven - put the pointed end into the drive socket on the right side of the oven wall first, and then press down the rod end to the drive socket on the left side of the oven wall.
8. Reset the time and begin to cook according to your recipe or the chart on page 8. If the meat does not rotate smoothly, you may need to reload it on the rotating set (distributing the weight differently).
9. When food is done, turn the heater and time controls to OFF position. Unplug the oven. Use the rotisserie tool to remove the rotating set - first lift up the left rotating wheel out of the drive socket, and then pull the right wheel out of the right drive socket. Place the food on a cutting board or platter. Let rest at least 5 minutes, then remove food from rotating set.

**Tip:** WE RECOMMEND CLEANING THE CRUMB/DRIP TRAY AFTER EACH USE!

(continued on page 8)

# HOW TO OPERATE

## ROTISSERIE CHART

Please note the cooking times and temperatures given here are only a guide; they may vary due to differences in meat size and temperature of refrigerated food. Desired doneness is based on personal preference. Adjust your cooking time and temperature for rare, medium, or well done.

FOOD	TEMP °F	INT. TEMP °F	TIME
Chicken 3-6 lbs.	450	165	1 Hr. 15-30 Mins.
Cornish Hen 3/4 to 1 1/2 lbs. ea.	425	165	18-30 Mins.
Duck 4-6 lbs.	425	165	1 Hr. 15-30 Mins.
Roast Beef 3-6 lbs.	450	135-160	1-2 Hrs.
Pork Spareribs 3-6 lbs.	450	170	2 Hrs. 15-30 Mins.
Pork Roast 3-6 lbs.	450	170	1-2 Hrs.
Ham, pre-cooked (boneless) 4-6 lbs.	425	140	1-2 Hrs.

**Using the KABOB RODS:** Load food on the kabob rods. Assemble the entire rotating set and stand it on the spit loading base (see page 7, steps 4 & 6). Poke the pointed end of the kabob rod through one of the holes on the top rotating wheel, and align the hooked end with a slot on the bottom wheel and squeeze into place. Space the kabob rods around the rotating set to distribute the weight evenly. Follow the steps on page 7 (step 7) for mounting the rotating set in the oven.

**Using the FOOD BASKET:** The food basket is perfect for foods that won't load on the rotating set (fish, vegetables, etc.). Spray the basket with cooking spray or wipe with oil to ease clean-up. Place food in the basket, evenly distributing the weight. Close the basket tightly over the food. The pointed ends of the top go into the bottom bracket with holes - you'll have to tip the top to insert points into holes (see diagram 1 on page 9); fasten

(continued on page 9)



# HOW TO OPERATE

the curled ends of the top in the bottom basket bracket with adjustable slots (see diagram 2 below). Mount the basket in the oven using the rotisserie tool (put the pointed end into the drive socket on the right side of the oven wall first, and then press down the rod end to the drive socket on the left side of the oven wall).

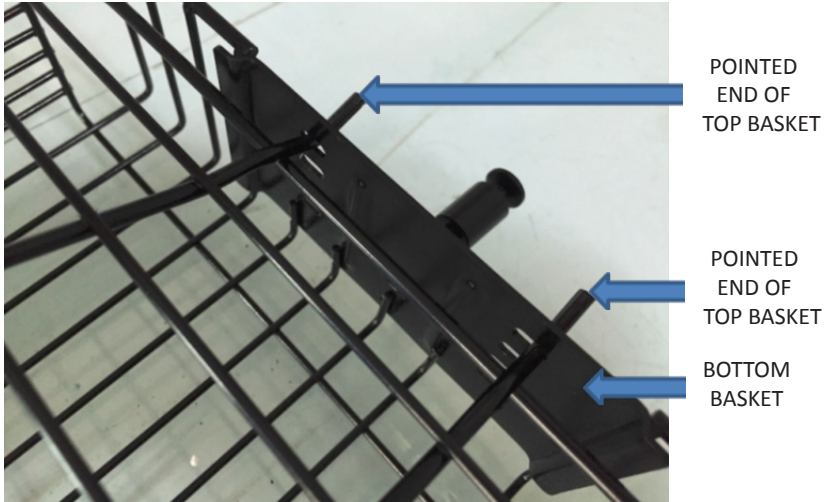

diagram 1

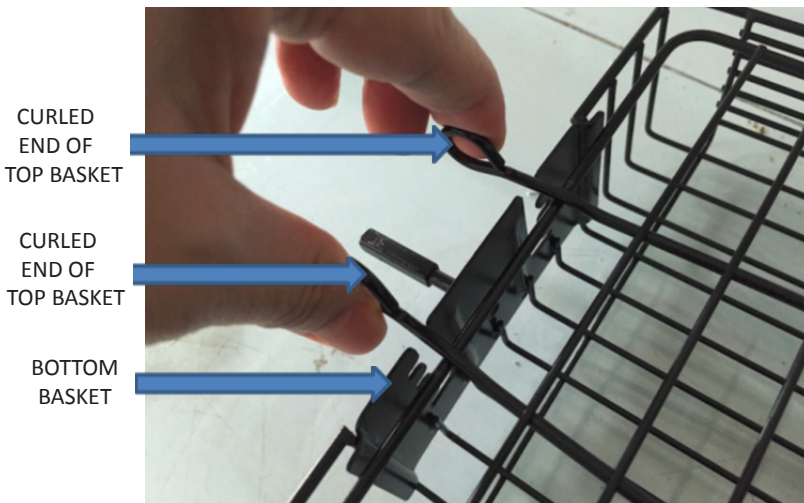

diagram 2

# HOW TO OPERATE

## ROASTING

1. Plug in the oven. Set temperature per recipe or per chart below and set the heater to ALL/ROTISSERIE.
2. Turn the time to 10 - 15 minutes to preheat the oven.
3. Place the rack on the middle or lower slot (whichever will fit food the best).
4. Place food on the roasting tray or other oven safe pan and put in the preheated oven.
5. Reset the time per recipe instructions.
6. When food is done, turn the heater and time controls to OFF position. Unplug the oven. Let rest at least 5 minutes before serving.

**Tip:** To protect and prolong the life of your enamel coated roasting tray, you can line the tray with aluminum foil (shiny side down).

### ROASTING CHART

Please note that the cooking times and temperatures given here are only a guide; they may vary due to differences in meat size and temperature of refrigerated food. Desired doneness is based on personal preference. Adjust your cooking time and temperature for rare, medium, or well done.

FOOD	TEMP °F	INT. TEMP °F	TIME
Chicken (whole)	350	165	18-20 Mins./lb.
Cornish Hen(s)	350	165	45 Mins. - 1.25 Hrs.
Turkey Breast	350	165	18-20 Mins./lb.
Ribeye, boneless	325-350	135-160	14-15 Mins./lb.
Standing Rib Roast	325	170	20-25 Mins./lb.
Brisket	375	150-160	25-30 Mins./lb.
Ham, pre-cooked (boneless)	325	140	20-25 Mins./lb.

# HOW TO OPERATE

## **BROILING**

1. Plug in the oven. Set temperature to 450°F and set the heater to UPPER.
2. Turn the time to 10 - 15 minutes to preheat the broiler.
3. Place the rack on the middle or upper slot.
4. Place food on the roasting tray or other oven safe pan (use cooking spray or wipe with cooking oil). Brush food with oil or sauce. Place food close to top heating element for top browning (but do not let food touch heating element).
5. Reset the time per recipe instructions, or per the chart below. Flip food halfway through cooking time and monitor closely to avoid burning.
6. When food is done, turn the heater and time controls to OFF" position. Unplug the oven.

### BROILING CHART

Please note the cooking times and temperatures given here are only a guide; they may vary due to differences in meat size and temperature of refrigerated food. Desired doneness is based on personal preference. Adjust your cooking time and temperature for rare, medium, or well done.

FOOD	TEMP °F	INT. TEMP °F	TIME
Chicken Breast (1")	450	165	20-30 Mins.
Fish Steak (1")	450	145	12-15 Mins.
Fish Fillet	450	until flaky	8-10 Mins.
Ribeye (1")	450	135-160	14-16 Mins.
Sirloin/Porterhouse (1")	450	135-160	14-16 Mins.
London Broil (1")	450	150-160	18-20 Mins.
Pork Chops (1")	450	160-170	25-28 Mins.

# HOW TO OPERATE

## **BAKING**

**Tip:** This oven is even big enough to cook a 12" pizza!

1. Plug in the oven. Set temperature per recipe and set the heater to ALL/ROTISSERIE.
2. Turn the time to 10 - 15 minutes to preheat the oven.
3. Place the rack on the middle or lower slot (whichever will fit food the best).
4. Place food on the roasting tray or other oven safe pan and put in the preheated oven.
5. Reset the time per recipe instructions.
6. When food is done, turn the heater and time controls to OFF position. Unplug the oven.

**Note:** Roasting bags are not recommended for use in this oven.

## **GRIDDLE/GRILL/FRY**

1. Plug in the oven. Set temperature to 450 °F and set the heater to UPPER.
2. Remove the lid.
3. Turn the time to 5 minutes to preheat the griddle top.
4. Place the food on the griddle top (use oil or butter per recipe), reset the timer and cook per recipe instructions.
5. When food is done, turn the heater and time controls to OFF position. Unplug the oven.

**Tip:** Use the griddle top for your side dish while you cook your main course in the oven.

# HOW TO OPERATE

## STEAMING

1. Plug in the oven. Set temperature to 450 °F and set the heater to UPPER.
2. Remove the lid.
3. Place the food in a shallow dish, on a rack, or on aluminum foil on the griddle top. Add water to cover the bottom of the griddle top (not exceeding half of the griddle depth).

**Note:** You do not want water to boil over, but you also do not want the griddle top to boil dry - so keep an eye on this as you steam.

4. Cover the food and water with the lid. Set the timer and cook per your recipe instructions or use the chart below.
5. When food is done, CAREFULLY remove the lid and food. Turn the heater and time controls to OFF position. Unplug the oven. Let cool completely before emptying remaining water from the griddle top.

FRESH VEGETABLE STEAMING CHART (cooking times may vary)

Asparagus	whole	3-7 minutes
Beans, green or wax	whole	6-10 minutes
Beets, small-medium	whole	35-40 minutes
Greens	whole leaves	3-9 minutes
Broccoli	split stalks	5-7 minutes
Brussels sprouts	whole	8-15 minutes
Carrots, baby	whole	10-12 minutes
Corn on the cob	whole, husked	7-10 minutes
Peas, snap	whole pods	5-6 minutes
Potatoes	large chunks	8-12 minutes
Potatoes, new	whole	15-20 minutes
Squash, butternut	large chunks	7-10 minutes
Turnips	large chunks	8-12 minutes
Sweet potatoes	large chunks	8-12 minutes
Zucchini	large chunks	4-8 minutes

# HOW TO OPERATE

## **TOASTING**

1. Plug in the oven. Set temperature to 450°F and set the heater to LOWER (for bottom toasting), UPPER (for top toasting), or ALL/ROTISSERIE (for bottom and top toasting).
2. Turn the time to 5 minutes to preheat the oven.
3. Place the rack in the desired slot.
4. Place food directly on the rack.
5. Reset the time per recipe instructions.
6. When food is done, turn the heater and time controls to OFF position. Unplug the oven.

## **WARMING**

1. Plug in the oven. Set temperature to 220°F-240°F and set the heater to LOWER, UPPER, or ALL/ROTISSERIE. When you select LOWER, place the rack closer to the lower heating element; when you select UPPER, place the rack closer to the top heating element. If you select ALL/ROTISSERIE, place food in the middle.
2. Place your food in the oven on an oven safe pan and heat until warm. Cover if needed.
3. When food is done, turn the heater and time controls to OFF position. Unplug the oven.

**Note:** Warming over 30 minutes is not recommended, as food might get dry.

# CLEANING & CARE

1. Turn off and unplug the oven. Always allow the appliance to cool completely before cleaning. Disassemble all parts.
2. Do not use abrasive brushes or pads, or harsh cleaning solutions.
3. Use a soft cloth, sponge or rubber spatula to remove any stuck-on food or residue. Wash cooking racks, trays and other accessories (including the griddle top and crumb/drip tray) in warm, soapy water. All of these items are also dishwasher safe.
4. Clean the oven door and interior with a damp cloth. Wipe the exterior with a damp cloth.
5. Do not immerse any electrical appliance, its cord or plug, into water.
6. Ensure all parts are dried thoroughly before reassembling and using this appliance.

# RECIPES

*Spice Rubs* - an easy, excellent way to add flavor and seal in juices when roasting or using a rotisserie.

1. Mix all ingredients together and pat generously on the meat.
2. Follow the rotisserie directions on page 7 and 8 or the roasting instructions on page 10, and use the charts on page 8 or 10 for times and temperatures for your cut of meat.
3. When done, let the meat rest at least 5 minutes before serving.

## *Chicken or Pork Rub*

2 T. kosher salt	½ T. dried rosemary
2 T. brown sugar	½ T. dry mustard
1 T. onion powder	½ T. ground cumin
1 T. garlic powder	½ T. dried thyme
1 T. smoked paprika	½ T. cayenne pepper
½ T. black pepper	

## *Beef or Venison Rub*

3 cloves fresh garlic, pressed	2 T. kosher salt
1 T. ground black pepper	1 T. ground coriander
1 T. smoked paprika	1 T. onion powder

# RECIPES

## *Corned Beef Hash with Fried Eggs*

1 T. butter or bacon drippings	1 clove garlic, minced
1 T. vegetable oil	½ red or green bell pepper
2 med. potatoes, cooked & cubed	2 eggs
¾ c. cabbage, cooked & chopped	salt & pepper
1 c. corned beef, cubed	hot sauce (optional)
½ med. onion, chopped	

1. Turn the heater to ALL/ROTISSERIE and the temperature to 375°F.
2. Heat the butter and oil on the griddle top.
3. Add potatoes and fry until they start to brown and get crispy (about 2-3 minutes).
4. Wipe the roasting tray with a little oil and put the cabbage and corned beef on it. Place the roasting tray on the middle rack in the oven.
5. Add the onion, garlic & bell pepper to the potatoes. Saute with the potatoes for 4-5 more minutes.
6. Remove the vegetables from the griddle top and add them to the cabbage and corned beef. Stir. Cook in the oven for 10 more minutes or until all heated through and crispy.
7. Add a little more oil or butter to the griddle top, if needed, and add the eggs. Salt & pepper to taste. When the eggs are done to your liking, serve them on top of the hash with hot sauce.

Serves 2



# RECIPES

## *Zucchini Patties*

1 medium zucchini, shredded	2 rings jalapeno, finely minced
½ medium onion, minced	salt & pepper
2 eggs	2 T. hot sauce
1 c. bread crumbs	2 T. ranch dressing

1. Turn the heater to ALL/ROTISSERIE and the temperature to 400° F for baking on the center rack.
2. Put the shredded zucchini in a thin towel and squeeze it into a ball over your sink to drain as much liquid as possible (patties will not hold together well if they are too wet).
3. Put the drained zucchini in a large bowl and mix in the onion, eggs, bread crumbs and jalapenos until well blended. Salt & pepper to taste.
4. Form the patties with your hands (make them thin so they will cook up nice and crispy).
5. Place the patties on parchment paper on a cookie sheet. Bake for 10 minutes, flip, then bake another 10 minutes.
6. In a small bowl, mix the hot sauce with the ranch dressing for a creamy, zesty sauce. Drizzle a little sauce over each patty and serve hot.

Makes 8 patties

## *Leftover Turkey Pasta Bake*

- ½ medium onion, diced
- 1 stalk celery, diced
- 1 clove garlic, minced
- ¼ t. dried oregano (or marjoram, basil, or rosemary)
- ¼ to ½ lb. turkey, cooked and chopped into bite-size pieces
- salt & pepper
- ½ lb. pasta (we used rotini), cooked & rinsed
- ½ jar (25 oz.) pasta sauce
- 4 oz. mozzarella, shredded

1. Turn the heater to ALL/ROTISSERIE and the temperature to 350° F for baking on the center rack. Turn the timer to STAY ON.
2. When the griddle top is warm, brown the onion and celery in a little olive oil until onions are translucent.
3. Add garlic and herbs. Stir well.
4. Blend in the turkey. When the turkey is heated through, add salt & pepper to taste. Stir.
5. Spray an oven safe pan or casserole dish with cooking spray. Put the turkey mixture with the cooked pasta and sauce in the pan. Stir. Top with the mozzarella.
6. Bake uncovered at 350° F for 20-30 minutes or until heated through.

*Variations: Add mushrooms, greens or olives (or all three!) to step #2.*

Serves 2-4

# RECIPES

## *Bacon Chocolate Chip Cookies*

1 c. butter	2 ¼ c. all-purpose flour
¾ c. granulated sugar	1 t. baking soda
½ c. packed brown sugar	1 c. semi-sweet chocolate chips
2 eggs	½ c. bacon, cooked and chopped
1 t. vanilla	

1. Turn the heater to ALL/ROTISSERIE and the temperature to 375° F for baking on the center rack. Turn the timer to STAY ON.
2. With a mixer on medium, cream butter and sugars until fluffy. Add eggs and vanilla and beat until well mixed.
3. In a separate bowl, whisk flour and baking soda together, then add slowly to sugar mixture, beating until combined. Mix in chocolate chips and bacon by hand.
4. Drop by tablespoon amounts (about 2 inches apart) onto an ungreased cookie sheet. Bake for 8 to 10 minutes, or until the edges turn golden brown.
5. Cool on cookie sheet for a few minutes, then remove and transfer to a wire rack to cool completely.

Makes 2 dozen cookies

# WARRANTY

Ginny's warrants this product free from defects in material and workmanship for one year from provable date of purchase.

Within this warranty period, Ginny's will repair or replace, at its option, defective parts at no charge, provided the product is returned, freight prepaid with proof of purchase to Ginny's. Allow 2-4 weeks for return shipping.

This warranty does not cover improper installation, misuse, abuse or neglect on part of the owner. Warranty is also invalid in any case that the product is taken apart or serviced by an unauthorized service station.

This warranty gives you specific legal rights and they may vary from state to state.

THE FOREGOING WARRANTIES ARE IN LIEU OF ALL OTHER WARRANTIES AND CONDITIONS, EXPRESS OR IMPLIED, INCLUDING BUT NOT LIMITED TO THOSE OF MERCHANTABILITY OR FITNESS FOR A PARTICULAR PURPOSE.



Ginny's, Inc.  
1112 7th Avenue  
Monroe, WI 53566

Customer Service: 800-544-1590  
8:00 a.m. to Midnight CST, Monday through Friday