



10-in-1 Food Processor Instruction Manual

Item 60244



Ginnys.com • 1.800.544.1590

IMPORTANT SAFEGUARDS

Thank you for purchasing a Ginny's Brand 10-in-1 Food Processor! This little item does it all. Enjoy!

TABLE OF CONTENTS

Important Safeguards	3
Save these Instructions	4
Specifications	5
Part Names	6-7
How to Operate	8-9
Attachment Operation	10-13
Cleaning and Care	14
Warranty	15

Before using your machine

1. Read these instructions carefully and retain for future reference.
2. Remove all packaging and any labels.
3. The blades and discs are very sharp, handle with care.
Always hold the knife blade by the finger grip at the top, away from the cutting edge.
4. Do not lift or carry the processor by the handle, the handle may break resulting in injury.
5. Always remove the knife blade before pouring contents from the bowl.
6. Keep hands and utensils out of the processor bowl and blender jug while connected to the power supply .
6. Switch off and unplug before fitting or removing any parts, after use or before cleaning.
7. Never use your fingers to push food down the feed tube. Always use the pusher supplied.
8. Before removing the lid from the bowl or blender/mill from the power unit: Switch off.
9. Wait until the attachments/blades have completely stopped.
Don't unscrew the blender jug or mill from the blade unit.
10. Allow all liquids to cool to room temperature before placing them in the blender jug.
11. Do not use the lid to operate the processor, always use the on/off switch and speed control.
12. Never use an unauthorized attachment.
13. Never leave the machine on unattended.
14. Never use a damaged machine, in case of any repairs, replacement of cord or plug, or adjustment, please contact Ginny's Customer Returns for details.
15. Never let the power unit, cord or plug get wet.
16. Don't let the wire hang over the edge of a table or worktop or touch hot surfaces.
17. Do not exceed the maximum capacities stated.
18. This appliance is not intended for use by persons (including children) with reduced physical, sensory or mental capabilities, or lack of experience and knowledge, unless they have been given supervision or instruction concerning use of the appliance by a person responsible for their safety.
19. Only use the appliance for its intended domestic use.

IMPORTANT SAFEGUARDS...cont'd.

20. Before plugging in, make sure your electricity supply is the same as the one shown on the underside of your machine.
21. This machine will be damaged and may cause injury if the Inter lock mechanism is forced.
22. Before using for the first time, remove all packaging and use caution handling the blade attachments as they are very sharp.
23. The covers on the attachments should be discarded as they are to protect the blade during manufacture and transit only.
24. Wash all parts see "cleaning and care".

No user-serviceable parts inside. A short cord is provided to reduce the hazards resulting of entanglement or tripping over a long cord. An extension cord may be used with care, however, the marked electrical rating should be at least as great as the electrical rating of this appliance. The extension cord should not be allowed to drape over the counter or tabletop where it can be pulled on by children or tripped over.

FOR HOUSEHOLD USE ONLY

This Cool Drink Machine is equipped with a polarized plug in which one prong is wider than the other. This is a safety feature, to reduce the risk of electrical shock. The plug will fit into a polarized outlet only one way. If you are unable to insert the plug into the electrical outlet, try reversing the plug. If the plug still does not fit, contact a qualified electrician. Do not attempt to modify the plug in any way.

SPECIFICATIONS

Rate:	120V 60Hz
Wattage:	650W

FUNCTION SPEEDS

TOOL ATTACHMENT	FUNCTION	SPEED	MAXIMUM CAPACITIES
Knife Blade	Grind meat, cut vegetables, make stuffing: cut both meat & vegs.	2	1.1 lbs. meat
		1-2	
		2	1 lb. meat
		2	
Dough Tool	Dough Making	2	1.1 lbs.flour 1-1/4 cup water
Discs: Slicing, shredding, chopping	Slicing/ shredding/ chopping food & vegetables	1-2	
Blending components: blender jug/ blender unit	Make jam, milk shake, soup, ice crushing	1-2	5 cups
Citrus press components	Citrus fruit juicing	1	
Mill components	Hot peppers, coffee beans, nuts, etc.	2	

PART NAMES



PART NAMES...cont'd.

FOOD PROCESSOR PARTS

1. Power Unit
2. Drive shaft
3. Bowl
4. Lid
5. Feed tube
6. Pushers
7. Safety interlock
8. Speed control

BLENDER/MILL PARTS

9. Sprinkler Lid
10. Mill Jar
11. Blending cap
12. Lid
13. Blender Jug
14. Sealing ring
15. Blade Unit

ADDITIONAL ATTACHMENTS

16. Knife Blade
17. Dough tool
18. Thick slicing/coarse shredding disc
19. Thin slicing/fine shredding disc
20. Fine(Julienne style)chopper disc
21. Geared citrus press
22. Spatula

HOW TO OPERATE

TO USE YOUR FOOD PROCESSOR:

1. Fit the detachable shaft onto the power unit.
2. Then fit the bowl. Place the handle towards the back and turn clockwise until it locks.
3. Fit an attachment over the drive shaft. Always fit the bowl and attachment onto the machine before adding ingredients.
4. Fit the lid ensuring the top of the drive



The handle should be on the upper right side of the base

Face the side with the speed control

shaft fits into the center of the lid. Do not use the lid to operate the processor,

5. Switch on and select a speed. The processor will not work if the bowl and lid are fitted incorrectly. Use the pulse (p) for short bursts. The pulse will operate as long as the control is held in position.
6. Reverse the above procedure to remove the lid, attachments and bowl. Always switch off before removing the lid.

Notes:

- The bowl and lid must be fitted correctly and locked into position to operate.
- Your processor is not suitable for crushing or grinding coffee beans, or converting granulated sugar to caster sugar.
- When adding almond essence or flavoring to mixtures avoid contact with the plastic as this may result in permanent marking

It is when the handles is on the left side of the base

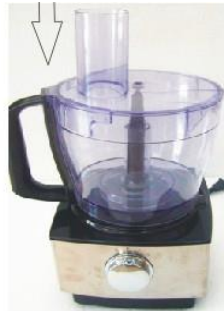

Turn the mixing bowl clockwise to lock into place



When the handle is on the middle of the right line of the base, the mixing bowl is locked

HOW TO OPERATE

TO USE YOUR BLENDER:

1. Fit the sealing ring into the blade unit. Leaking will occur if the seal is damaged or not fitted correctly.
2. Screw the jug onto the blade unit.
3. Put your ingredients into the jug.
4. Put the blending cap in the lid, then turn the lid in a clockwise direction to lock onto the jug.
5. Fix the blender jug onto the power unit

Turn lid clockwise with the lid; clip lock into the bowl handle



6. Select a speed or use the pulse control. Allow all liquids to cool to room temperature before placing them in the blender jug.

Hints:

- When making mayonnaise, put all the ingredients, except the oil into the blender jug. Then while the machine is operating, pour the oil into the blending cap and let it run through.
- Thick mixtures like pates and dips, may need scraping down. If it's difficult to process, add more liquid.
- When crushing ice, use the pulse in short bursts
- Don't process hot peppers – they may damage the plastic.
- The machine won't work if the blender jug is fitted incorrectly.
- Don't put dry ingredients into the blender jug before switching on. If necessary, cut them into pieces; remove the blending cap; then with the machine running, drop them through one by one.
- Don't use the blender jug as a storage container. Keep it empty before and after use.
- Never blend more than 1 1/2 quart (50 fl oz) – less for frothy liquids like milkshakes.



It is locked down

ATTACHMENT OPERATION

KNIFE BLADE/DOUGH TOOL

1. The knife blade is the most versatile of all the attachments.
2. The length of the processing time will determine the texture you would like to achieve.
3. For coarser textures use the pulse control.
4. Use the knife blade for cake and pastry making, chopping, raw and cooked meat, vegetables, nuts, pate, dips, pureeing, soups.
5. It can also make bread crumbs from biscuits and bread. It can also be used for yeasted dough mixes.
6. Use the dough tool for both yeasted and non-yeasted mixes: eg cookie dough.

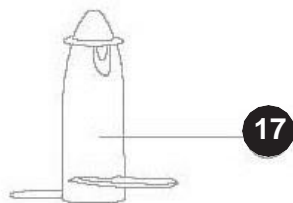
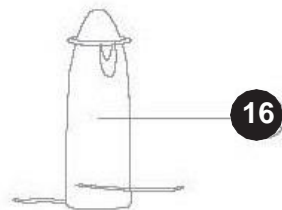

KNIFE BLADE

1. Cut food such as meat, bread, vegetables into cubes approximately 3/4in. before processing.
2. Biscuits should be broken into pieces and added down the feed tube while the machine is running.
3. When making pastry use fat or butter straight from the fridge cut into 3/4in. cubes.
4. Take care not to over-process.

DOUGH TOOL

1. Place the dry ingredients in the bowl and add the liquid down the feed tube while the machine is running. Process until a smooth elastic ball of dough is formed this will take 60 seconds.
2. Re-knead by hand only. Re - kneading in the bowl is not recommended as it may cause the processor to become unstable.

ATTACHMENT OPERATION

SLICING/SHREDDING DISCS

Reversible Slicing/Shredding discs:
thick/thin

1. Use the shredding side for shredding cheese, carrots, potatoes and foods of a similar texture.
2. Use the slicing side for cheese, carrots, potatoes, cabbage, cucumber, beetroot and onions.

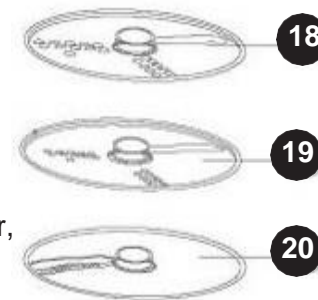

Fine (julienne style) chopper disc

1. Use to cut: potatoes for julienne style French fries, firm ingredients for salads, garnishes, casseroles and stir fries(egg carrot, cucumber, onions).

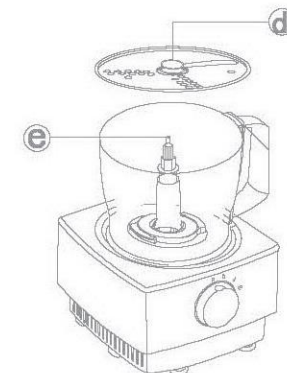

Safety

Never remove the lid until the cutting disc has completely stopped.

Handle the cutting discs with care - they are extremely sharp.

HOW TO USE THE CUTTING DISCS

1. Fit the drive shaft and bowl onto the power unit.
2. Holding by the center grip, place the disc onto the drive shaft with the selected cutting blade facing up.
3. Fit the lid.
4. Choose which size feed tube you want to use. The pusher contains a smaller feed tube for processing individual items or thin ingredients. To use the small feed tube - first put the large pusher inside the feed tube. To use the large feed tube - use both pushers together.
5. Put the food in the feed tube.
6. Switch on and push down evenly with the pusher.

ATTACHMENT OPERATION

Hints

- Use fresh ingredients.
- Don't cut food too small. Fill the width of the large feed tube. This prevents the food from slipping sideways during processing. Alternatively use the small feed tube.
- When using the chopper disc, place ingredients horizontally.
- When slicing or shredding: food placed upright comes out shorter than food placed horizontally.
- There will always be a small amount of waste on the plate or in the bowl after processing.

Never put your fingers in the feed tube.

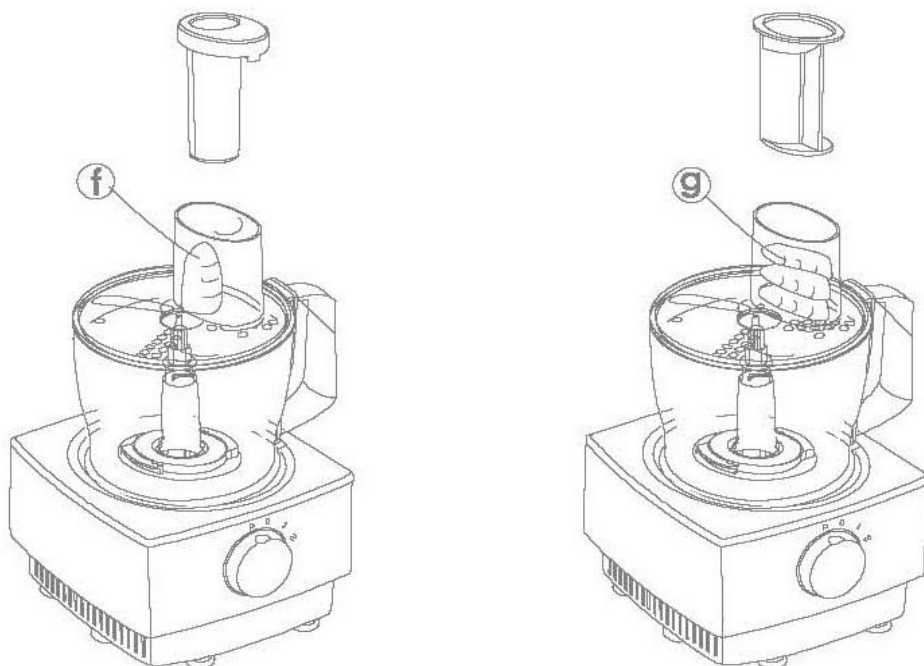

ATTACHMENT OPERATION

CITRUS PRESS

Use the citrus press to squeeze the juice from citrus fruits (e.g. oranges, lemons, limes and grapefruits).

HOW TO USE THE CITRUS PRESS

1. Fit the drive shaft and bowl onto the power unit.
2. Fit the sieve (2) into the bowl - ensuring the sieve handle is locked into position directly over the bowl handle.
3. Place the cone (1) over the drive shaft turning until it drops all the way down.
4. Cut the fruit in half. Then switch on and press the fruit onto the cone.
5. The citrus press will not operate if the sieve is not locked correctly.

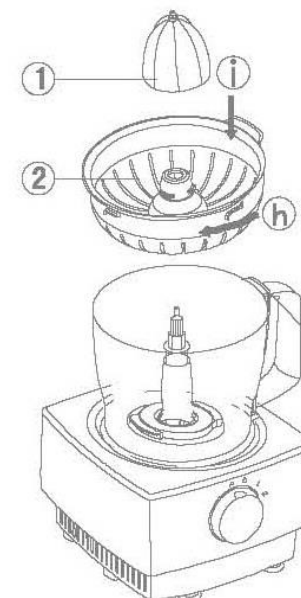

MILL

Use the mill for milling herbs, nuts and coffee beans.

1. Blade Unit
2. Sealing Rng
3. Jar
4. Sprinkler Lid

HOW TO USE YOUR MILL

1. Put your ingredients into the jar. Fill it no more than half full.
2. Fit the sealing ring into the blade unit.
3. Turn the blade unit upside down. Lower it into the jar, blades down.
4. Screw the blade unit onto the jar until it is finger tight.
5. Fix the mill onto the power unit and turn the mill clockwise to lock on the base.
6. Switch on to maximum speed or use the pulse control.
7. After milling, you can replace the blade unit with the sprinkler lid and shake out your food.
8. The sprinkler lid is not airtight.

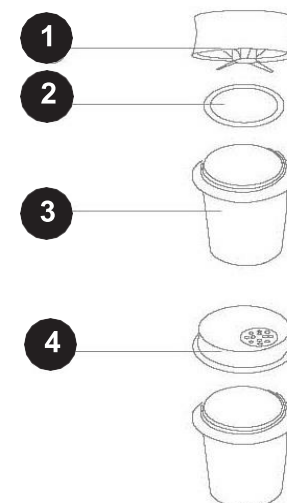

CLEANING & CARE

1. Always switch off and unplug before cleaning.
2. Handle the Knife blades(16) and cutting discs(19)(20) with care - they are extremely sharp.
3. Some foods may discolor the plastic. This is perfectly normal and won't harm the plastic or affect the flavor of your food. Rub with a cloth dipped in vegetable oil to remove the discoloration.
4. Wipe with a power unit(1) damp cloth, then dry. Ensure that the interlock area is always clear of food debris.
5. Empty the jug/jar(13) before unscrewing it from the blade unit(15).
6. Wash the jug/jar(13) by hand.
7. Remove and wash the sealing ring(14).
8. Do not touch the Knife Blade(16). Brush them clean using hot soapy water, then rinse thoroughly under the tap. Don't immerse the blade unit(15) in water.
9. Leave to dry upside down.
10. All other parts Wash by hand then dry.
11. Alternatively they can be washed on the top rack of your dishwasher. A short low temperature program is recommended

WARRANTY

Ginny's warrants this product free from defects in material and workmanship for one year from provable date of purchase.

Within this warranty period, Ginny's will repair or replace, at its option, defective parts at no charge, provided the product is returned, freight prepaid with proof of purchase to Ginny's.

Allow 2-4 weeks for return shipping.

This warranty does not cover improper installation, misuse, abuse or neglect on part of the owner. Warranty is also invalid in any case that the product is taken apart or serviced by an unauthorized service station.

This warranty gives you specific legal rights and they may vary from state to state.

THE FOREGOING WARRANTIES ARE IN LIEU OF ALL OTHER WARRANTIES AND CONDITIONS, EXPRESS OR IMPLIED, INCLUDING BUT NOT LIMITED TO THOSE OF MERCHANTABILITY OR FITNESS FOR A PARTICULAR PURPOSE.



Customer Service

Phone: 1•800•544•1590

8:00 am to Midnight, Monday through Friday