



**RETRO .9 CU. FT.
MICROWAVE OVEN**
User Guide

Item: 732215

*Recipes
Inside!*



Ginnys.com • 800-544-1590

 *Facebook.com/GinnysBrand*

 *Pinterest.com/GinnysBrand*

 *Ginnys.com/Blog*

Thank you for purchasing this Ginny's Brand Retro .9 Cu. Ft. Microwave oven! You'll be delighted how the fun style will perk up your kitchen counter, and its reliability will impress you — for years to come. Enjoy!

TABLE OF CONTENTS

Important Safeguards	3-4
Electrical Safety	4
Specifications	5
Get to Know Your Appliance	5-6
How to Operate	7-10
Cleaning & Care	11
Recipes	12-15
Warranty	16

IMPORTANT SAFEGUARDS

READ CAREFULLY BEFORE USING AND SAVE THESE INSTRUCTIONS!

- FOR HOUSEHOLD USE ONLY. Do not use this appliance for other than its intended use.
- REMOVE all packaging materials and labels before first use.
- WASH all removable parts and wipe down the inside of the oven before first use. See Cleaning & Care.
- A SHORT CORD is provided to reduce the hazards resulting from entanglement or tripping. Do not drape the cord over the counter or tabletop, where it can be pulled on or tripped over.
- We do not recommend using an extension cord with this appliance. However, IF AN EXTENSION CORD IS USED, the marked electrical rating should be at least as great as the electrical rating of this appliance.
- CLOSE SUPERVISION is necessary when using this appliance near CHILDREN.
- A FIRE may occur if this appliance is used near FLAMMABLE MATERIALS. REMOVE TWIST TIES. DO NOT overcook food. DO NOT use aluminum foil, metal utensils, or styrofoam in this oven. DO NOT place the oven or its cord on or near a heated surface. IF MATERIALS INSIDE THE OVEN SHOULD IGNITE, KEEP OVEN DOOR CLOSED, TURN OVEN OFF, AND DISCONNECT THE POWER CORD OR SHUT OFF POWER AT THE CIRCUIT BREAKER PANEL.
- This appliance should always be used on a STABLE, DRY, HEAT-RESISTANT SURFACE.
- Do not use an accessory or attachment not recommended by Ginny's, as this may cause injury, or damage the appliance.
- Keep hands, hair and clothing away from all MOVING PARTS.
- Always use OVEN MITTS when handling hot food or appliances. Do not attempt to move an appliance when it is hot, or has hot contents.
- DO NOT ATTEMPT TO OPERATE THIS OVEN WITH THE DOOR OPEN. Open-door operation can result in harmful exposure to microwave energy. DO NOT TAMPER WITH THE DOOR SAFETY LOCKS. DO NOT ALLOW FOOD OR CLEANER RESIDUE TO BUILD-UP AROUND DOOR AREA.
- Products such as whole eggs in the shell and sealed containers (closed glass jars, sealed plastic containers) should not be heated in this oven, as they may EXPLODE from built-up pressure.

(continued on page 4)

IMPORTANT SAFEGUARDS

- Liquids can be OVERHEATED BEYOND THE BOILING POINT WITHOUT APPEARING TO BE BOILING due to surface tension of the liquid. Visible bubbling or boiling when the container is removed from the oven is not always present. THIS COULD RESULT IN VERY HOT LIQUIDS SUDDENLY BOILING OVER WHEN A SPOON OR OTHER UTENSIL IS INSERTED INTO THE LIQUID.
- DO NOT HEAT OIL or fat in large quantities (like for deep frying) in this microwave!
- Pierce foods with heavy skins, such as whole potatoes or whole squash, before cooking, as they may EXPLODE from built-up pressure.
- Do not cover or block any openings on the appliance. Allow 4" for the back, 8" above and 2" on the sides between the oven and wall or cabinet.
- This oven generates, uses, and can radiate radio frequency energy and may cause interference to your TV or radio. Try to correct interference by increasing the separation between the equipment and the oven, or connect the equipment and oven to different outlets on different circuits. Consult an experienced radio/TV technician for help.
- Do not use outdoors. Do not use this product near water or in a location with high humidity.
- NO SERVICEABLE PARTS INSIDE THIS APPLIANCE.
- DO NOT USE AN APPLIANCE WITH A DAMAGED CORD OR PLUG, OR AFTER THE APPLIANCE MALFUNCTIONS, OR HAS BEEN DAMAGED IN ANY MANNER.

ELECTRICAL SAFETY

This appliance is equipped with a three-prong grounding plug. This is a safety feature to reduce the risk of electrical shock. Using an extension cord is not recommended with this appliance. It is recommended that an electrical outlet serving ONLY this appliance be used. This outlet must be properly installed and grounded. If you have any questions about the grounding or electrical instructions, contact a qualified electrician. Do not attempt to modify the plug in any way. Ginny's cannot accept any liability for damage or injury resulting from failure to observe these safety procedures.

SPECIFICATIONS

<i>OUTPUT</i> REQUIREMENTS	120 v/60 Hz/900 W
POWER RATING <i>INPUT</i>	120 v/60 Hz/1350W
CAPACITY	.9 CU FT
CORD LENGTH	40"
OUTSIDE DIMENSIONS	11" H × 19" L × 15" D
INSIDE DIMENSIONS	8 1/2" H × 13 1/2" W × 12 1/2" D
NET WEIGHT	APPROXIMATELY 30 LBS.
MODEL	P90D23YL-Q3

GET TO KNOW YOUR APPLIANCE

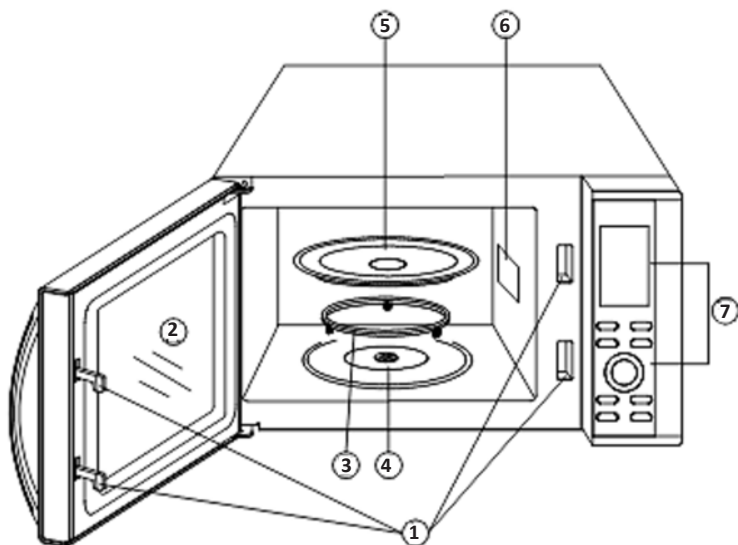

1. Door Safety Lock System
2. Oven Window
3. Turntable Ring
4. Turntable Shaft
5. Glass Turntable
6. Wave Guide (Mica Plate)
7. Control Panel (diagram page 6)

(continued on page 6)

GET TO KNOW YOUR APPLIANCE

DISPLAY SCREEN
shows time, timer, weight, and indicators for multi stage cooking, defrost, pre-set, and child lock.

POWER
set power level
(page 9)

PRE-SET
set a delayed
cooking
program (page 9)

MENU/TIME DIAL
turn counter-clock-
wise to select AUTO
COOK MENU; turn
clockwise to set
cooking time.

KITCHEN TIMER
(page 7)

WEI. DEF.
(*Weight Defrost*)
- (page 7)

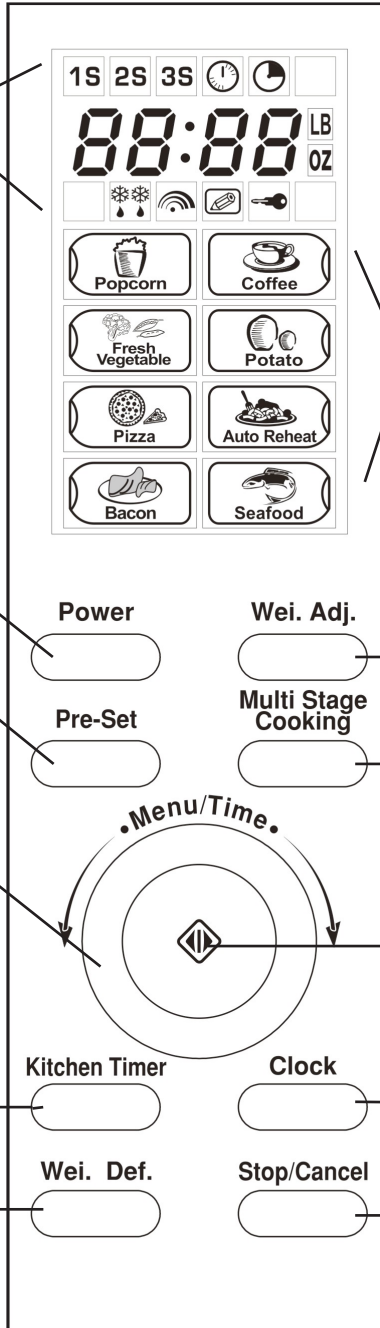

AUTO COOK MENU
(page 8)

WEI. ADJ. (*Weight Adjust*) - (pages 7-8)

MULTI-STAGE COOKING
(page 10)

START BUTTON

CLOCK (page 7)

STOP/CANCEL
(page 7)

HOW TO OPERATE

WARNING: ALWAYS USE OVEN MITTS WHEN HANDLING HOT FOOD!

Stop/Cancel: Stop or reset the oven. Press once to pause or twice to cancel any function.

Setting the Clock:

1. Press and hold CLOCK for 3 seconds.
2. Select the 24-hour cycle (military time) or the more common 12-hour cycle on the display screen by touching CLOCK once or twice.
3. Turn the MENU/TIME DIAL until the correct hour is shown.
4. Press CLOCK.
5. Turn MENU/TIME DIAL until the correct minutes are shown.
6. Press CLOCK to end.

Using the Kitchen Timer:

1. Press KITCHEN TIMER once.
2. Turn the MENU/TIME DIAL to select the desired amount of time (from 10 seconds to one hour).
3. Press START.
4. One beep will sound when your time is up.

Using Defrost:

1. Place food to be defrosted into the oven.
2. Press WEIGHT DEFROST once.
3. Press WEIGHT ADJUST as needed to show the desired weight on the display screen (4 oz. - 3 lbs. 15 oz.)
4. Press START.
5. The microwave will stop and beep three times during the defrosting time to let you turn the food over. When this happens, rearrange food, and press START to resume defrosting.
6. When defrosting time is finished, four beeps will sound.

HOW TO OPERATE

Tip: Only use dishes that are marked “*microwave safe*”. Discontinue using any dish which becomes very hot when used in a microwave oven.

Using Quick Start:

1. Press START  to quickly set cooking time—each press adds more time in 30 second increments. When you stop pressing, the oven will begin heating at full power level.
2. When cooking time is finished, four beeps will sound.

Using the Auto Cook Menu: With these choices, you won’t have to worry about setting the time or the power level.

1. Turn MENU/TIME DIAL counter-clockwise to select food.
2. Press WEIGHT ADJUST to select options for weight or number of servings (see chart below).
3. Press START.
4. When cooking time is finished, four beeps will sound.

FOOD	OPTIONS
Popcorn	3.5 oz. only
Coffee	1, 2, or 3 cups
Fresh Vegetables	7 oz., 11 oz., 14 oz., 1 lb. 2 oz., or 1 lb. 5 oz.
Potato	1, 2, or 3 potatoes
Pizza	5 oz., 11 oz., or 1 lb.
Auto Reheat	7 oz., 11 oz., 14 oz., 1 lb. 2 oz., 1 lb. 5 oz., or 1 lb. 12 oz.
Bacon	4 oz., 7 oz., or 11 oz.
Seafood	7 oz., 11 oz., 14 oz., 1 lb. 2 oz., or 1 lb. 5 oz.

HOW TO OPERATE

Programming Power Level and Time:

1. Press POWER to select a cooking power.

POWER	COOKING POWER (DISPLAY SCREEN)
Press 1 time	100% (P-HI)
Press 2 times	90% (P-90)
Press 3 times	80% (P-80)
Press 4 times	70% (P-70)
Press 5 times	60% (P-60)
Press 6 times	50% (P-50)
Press 7 times	40% (P-40)
Press 8 times	30% (P-30)
Press 9 times	20% (P-20)
Press 10 times	10% (P-10)

2. Turn MENU/TIME to set desired cooking time (0-60 minutes).
3. Press START.
4. When cooking time is finished, four beeps will sound.

Using Pre-set: Set a delayed cooking program. **Make sure your clock is set with the current time before setting a delay start time!**

1. Set desired cooking program: Defrost, Power Level/Time, or Auto Cook Menu (see instructions on pages 7-9), but **DO NOT PRESS START**.
2. Press PRE-SET.
3. Turn MENU/TIME to set the delay time hour (1-12 hours).
4. Press PRE-SET.
5. Turn MENU/TIME to set the delay time minutes (1-59 minutes).
6. Press START.
7. When cooking time is finished, four beeps will sound.

HOW TO OPERATE

Multi-Stage Cooking: Some recipes may require setting different power levels (3 stages can be set). During multi-stage cooking, indicator lights in the display screen will show the current cooking stage.

1. Stage 1 - set a Power Level/Time program, but **DO NOT PRESS START**.
2. Press MULTI-STAGE COOKING.
3. Stage 2 - set another Power Level/Time cooking program.
4. Press MULTI-STAGE COOKING.
5. Stage 3 - set another Power Level/Time cooking program.
6. Press START.
7. One beep will sound when the cooking switches from one stage to the next. When all cooking stages are complete, four beeps will sound.

Child Lock: While the child lock is set, the oven cannot be operated.

1. Press and hold STOP/CANCEL for 3 seconds—a beep will sound and the child lock indicator light will show on the display screen.
2. To cancel, press and hold STOP/CANCEL for 3 seconds until lock indicator light on display screen goes off.

Auto Reminder: After cooking is over, the oven will beep once every two minutes until the oven door is opened or STOP/CANCEL is pressed.

Tips:

- For even microwave cooking, place the thickest parts of food toward the outside of your dish.
- Rearrange food halfway through cooking time by turning over, and moving food in the center of the dish to the outside.
- Covering your food prevents spattering and helps it to cook more quickly and evenly.

CLEANING & CARE

1. Turn off the microwave oven.
2. Always allow the appliance to cool completely before cleaning.
3. The oven should be cleaned regularly. **Failure to maintain the oven in a clean condition could affect the life of the appliance and/or result in a hazardous situation (health hazard or fire hazard).**
4. When food splatters, or spilled liquids adhere to oven walls, wipe with a damp cloth. A mild detergent may be used if the oven gets very dirty. **Do not use abrasive cleaners, brushes or pads, as these items may damage the interior.**
5. It is important to keep the wave guide clean. Excessive build-up of splattered food could prevent the microwaves from passing through to cook/heat food. **DO NOT REMOVE THE WAVE GUIDE.**
6. The glass turntable and turntable ring may be washed in mild, soapy water, or in a dishwasher (ring on top rack only).
7. The exterior surfaces should be cleaned with a damp cloth. To prevent damage to the operating parts inside the oven, water should not be allowed to seep into the ventilation openings.
8. Wipe the window on both sides with a damp cloth to remove any spills or splatters.
9. Do not allow the control panel to become wet. Clean with a soft, damp cloth. When cleaning the control panel, leave the oven door open to prevent accidentally turning on the oven.
10. Do not immerse any electrical appliance, its cord, or its plug, into water.

RECIPES

Italian Chicken Breasts

½ c. seasoned bread crumbs 2 chicken breasts, skinned
¼ c. Parmesan cheese, grated 1 c. pasta sauce
1 egg 2 oz. mozzarella cheese, grated

1. Mix the bread crumbs and Parmesan in a shallow bowl.
2. Beat the egg in another shallow bowl.
3. Dip the chicken in the egg, then roll in the bread crumb mixture to coat fully.
4. Place the coated chicken in the bottom of a microwave-safe dish with cover (I used a glass casserole dish).
5. Cover and microwave at full power for 5 minutes. Turn the chicken with tongs. Pour the sauce over the chicken.
6. Cover and cook another 4 minutes at full power.
7. Add the mozzarella to the top of the chicken and sauce. Cover and cook 1 more minute or until the cheese is melted.
8. Let stand, covered, about 3 minutes. Chicken should reach 165° F when done.
9. Serve over cooked pasta.

Serves 2

Easy Cheesy Cauliflower with Mustard

1 head cauliflower, rinsed, leaves trimmed
½ c. mayonnaise
1 T. prepared mustard
1 t. dry mustard
2-4 oz. cheddar cheese, shredded
salt & pepper to taste

(continued on page 13)

RECIPES

1. Place the cauliflower head in a microwave-safe dish with cover (I used a glass casserole dish), stem down.
2. Cover and cook on full power 7 minutes (cauliflower should be pretty tender, but not *mushy* – add more time if needed).
3. Mix mayonnaise and both mustards in a small bowl.
4. Using a pastry brush, coat the cauliflower with the mayonnaise mixture. Sprinkle the cheese on top.
5. Cover and cook for 1 more minute on high, or until the cheese is melted.
6. Add salt and pepper to taste.

Serves 4

Microwave Apple Crisp

- | | |
|----------------------------------|-----------------------|
| 1 can (24 oz.) apple pie filling | 2 T. brown sugar |
| ¼ c. Bisquick® | 3 T. butter, softened |
| ¼ c. quick oats | vanilla ice cream |
| ½ t. cinnamon | caramel syrup topping |

1. Using four small microwave-safe bowls or cups, split the apple pie filling evenly in each.
2. In a small mixing bowl, add the Bisquick®, oats, cinnamon, brown sugar and butter. Stir/mash with a fork until crumbly.
3. Sprinkle the crumbly topping over the apple pie filling (put even amounts in each bowl or cup).
4. Loosely cover each bowl or cup with a paper towel or wax paper. Place one or two in the microwave at once, and cook on HIGH four minutes, or until heated through.
5. Let stand uncovered for five minutes, then serve with vanilla ice cream and caramel syrup.

Serves 4

Pork Ribs

- | | |
|-----------------------|---|
| 2-3 lbs. pork ribs | 1 can (10-15 oz.) tomato sauce |
| 1 large onion, minced | 2-3 T. hot sauce (or more to taste) |
| 2 T. brown sugar | ½ t. salt (add more or less to taste) |
| 2 T. cider vinegar | ¼ t. pepper (add more or less to taste) |
| 1 t. prepared mustard | |

1. Cut ribs to fit your microwave-safe dish with cover (I used a glass casserole dish).
2. Mix remaining ingredients in a medium size bowl.
3. Dip ribs in sauce to fully coat, and put ribs in the microwave-safe dish. Pour remaining sauce over the top of the ribs.
4. Cover and cook on 50% power for 15 minutes.
5. Using tongs, turn rib pieces. Cover and cook on 50% power for another 15 minutes.
6. When done, meat should be tender and reach 170°F. (If additional time is needed, add in 5 minute increments.)
7. Add more salt and pepper to taste.

Serves 2

Quick and Easy Microwave Fudge

- | | |
|---|-----------------------|
| 2 packs (8 squares each) semi-sweet chocolate | ¼ t. salt |
| 1 can (14 oz.) sweetened condensed milk | 1 c. walnuts, chopped |
| 2 t. vanilla extract | butter |

1. Place half the chocolate and half the milk in a microwave-safe bowl. Heat on HIGH for one minute, stir. Heat on HIGH for another minute. Repeat with second half of chocolate and milk.
2. Combine and stir chocolate mixture until completely smooth.
3. Mix in vanilla, salt and walnuts. When blended well, pour into a cake pan or cookie sheet that has been lightly greased with butter.
4. Refrigerate until firm (about 2 hours), then cut into approximately 30 pieces.

RECIPES

Twice Baked Potatoes

4 medium size baking potatoes	¼ t. garlic powder
3-4 green onions, sliced	2-3 T. cheddar cheese, grated
2 T. butter	2-3 T. Parmesan cheese, grated
½ c. milk, heated	pepper, to taste
½ t. salt (or more to taste)	paprika, to taste

1. Scrub potatoes well, then bake per instructions on page 8. Let cool until able to handle.
2. Cut potatoes in half, lengthwise. Using a tablespoon, scoop out the cooked potato and place it in a mixing bowl (take special care to keep the potato skins intact).
3. Mash the potatoes. Add the onions, butter, milk, salt and garlic powder. Whip potatoes until smooth (use a mixer if you have one to make this easier).
4. Spoon the potato mixture back into the potato skins and arrange on a microwave-safe plate. Cook on HIGH for 2 minutes.
5. Sprinkle the potatoes with both cheeses. Heat again on HIGH for another 2 minutes or until cheese is melted.
6. Sprinkle the potatoes with pepper and paprika. Let cool for a minute or 2.
7. Serve with sour cream, bacon bits, or your favorite toppings.

Serves 6-8

WARRANTY

Ginny's warrants this product free from defects in material and workmanship for one year from provable date of purchase.

Within this warranty period, Ginny's will repair or replace, at its option, defective parts at no charge, provided the product is returned, freight prepaid with proof of purchase to Ginny's. Allow 2-4 weeks for return shipping.

This warranty does not cover improper installation, misuse, abuse or neglect on part of the owner. Warranty is also invalid in any case that the product is taken apart or serviced by an unauthorized service station.

This warranty gives you specific legal rights and they may vary from state to state.

THE FOREGOING WARRANTIES ARE IN LIEU OF ALL OTHER WARRANTIES AND CONDITIONS, EXPRESS OR IMPLIED, INCLUDING BUT NOT LIMITED TO THOSE OF MERCHANTABILITY OR FITNESS FOR A PARTICULAR PURPOSE.



LISTED

(Microwave Oven)

<23FJ>

E193295

Ginny's, Inc.
1112 7th Avenue
Monroe, WI 53566

Customer Service: 800-544-1590
8:00 a.m. to Midnight CST, Monday through Friday