



6-SLICE TOASTER OVEN WITH ROTISSERIE

User Guide

Item: 735233

*Recipes
Inside!*



Ginnys.com • 800-544-1590

 *Facebook.com/GinnysBrand*

 *Pinterest.com/GinnysBrand*

 *Ginnys.com/Blog*

Thank you for purchasing a Ginny's Brand 6-Slice Toaster Oven with Rotisserie. It's like having a mini-kitchen in one small appliance! Not only can it toast several pieces of bread at once, but it also bakes, broils, roasts and warms—without taking up the energy of a full-sized oven. Enjoy!

TABLE OF CONTENTS

Important Safeguards	3
Electrical Safety and Specifications	4
Get to Know Your Appliance	5
How to Operate	6-9
Cleaning & Care	10
Recipes	11-15
Warranty	16

IMPORTANT SAFEGUARDS

READ CAREFULLY BEFORE USING AND SAVE THESE INSTRUCTIONS!

- FOR HOUSEHOLD USE ONLY. Do not use this appliance for other than its intended use.
- REMOVE all packaging materials and labels before first use.
- WASH all removable parts before first use. See Cleaning & Care.
- A SHORT CORD is provided to reduce the hazards resulting from entanglement or tripping. Do not drape the cord over the counter or tabletop, where it can be pulled on or tripped over. Never wrap the cord tightly around the appliance, as this could cause the cord to fray or break.
- We do not recommend using an extension cord with this appliance. However, IF AN EXTENSION CORD IS USED, the marked electrical rating should be at least as great as the electrical rating of this appliance.
- CLOSE SUPERVISION is necessary when using this appliance near CHILDREN.
- A fire may occur if this appliance is used near FLAMMABLE MATERIALS, including curtains, towels, walls, etc. Do not place any paper, plastic, or other non-food items in the appliance. Do not place the appliance or its cord on or near a heated surface, or in a heated oven.
- This appliance should always be used on a STABLE, DRY, HEAT-RESISTANT SURFACE. Do not use near water.
- Keep at least 4" of space between this appliance and walls or cabinets.
- Do not use an accessory or attachment not recommended by Ginny's, as this may cause injury, or damage the appliance.
- Keep hands, hair and clothing away from all MOVING PARTS.
- Always use OVEN MITTS when handling hot food or appliances. Do not attempt to move an appliance when it is hot, or has hot contents.
- Do not use outdoors.
- Turn OFF AND UNPLUG this appliance when not in use.
- NO SERVICEABLE PARTS INSIDE THIS APPLIANCE.
- DO NOT USE AN APPLIANCE WITH A DAMAGED CORD OR PLUG, OR AFTER THE APPLIANCE MALFUNCTIONS, OR HAS BEEN DAMAGED IN ANY MANNER.

ELECTRICAL SAFETY

This appliance is equipped with a polarized plug in which one prong is wider than the other. This is a safety feature to reduce the risk of electrical shock. The plug should be attached to the appliance before connecting to an electrical outlet. The plug will fit into a polarized outlet only one way. If you are unable to insert the plug into the outlet, try reversing the plug. If it still does not fit, contact a qualified electrician. Do not attempt to modify the plug in any way. Ginny's cannot accept any liability for damage or injury resulting from failure to observe these safety procedures.

SPECIFICATIONS

POWER RATING	120 V, 60 HZ, 1300 W
CORD LENGTH	36"
DIMENSIONS	19.5" X 14" X 10.5"
MODEL	CS1803B

GET TO KNOW YOUR APPLIANCE

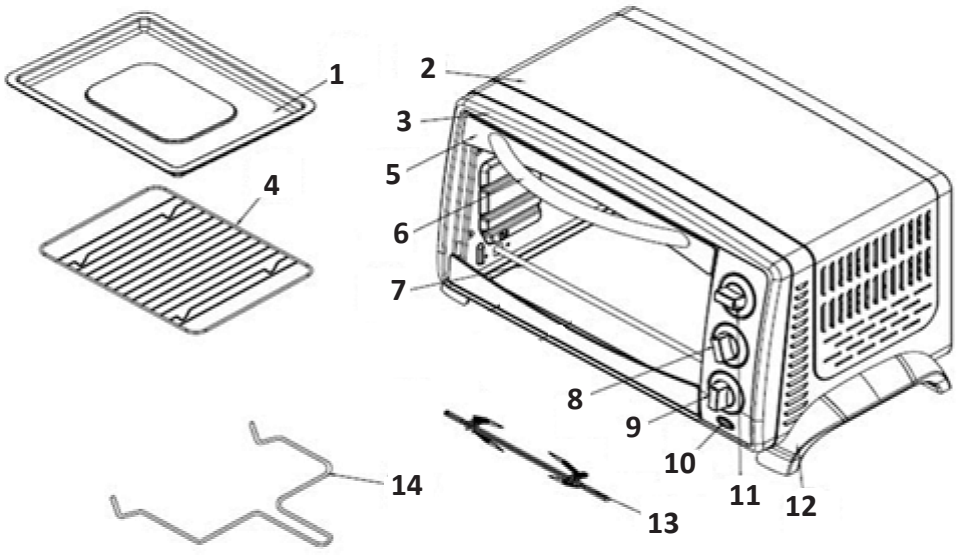

- 1. Bake Tray/Drip Pan
- 2. Housing
- 3. Upper Heating Elements (not shown)
- 4. Wire Rack
- 5. Door
- 6. Door Handle
- 7. Lower Heating Elements
- 8. Function Control Knob
- 9. Timer/Stay On Control Knob
- 10. Power Indicator Light
- 11. Temperature Control Knob
- 12. Base
- 13. Rotisserie Spit and Forks
- 14. Rotisserie Removal Tool

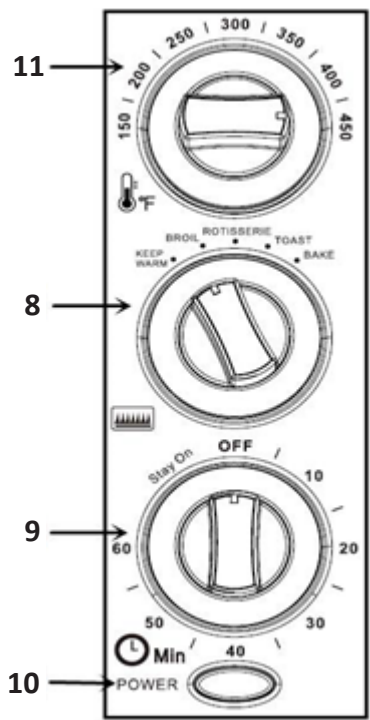

HOW TO OPERATE

Tip: Before using your toaster oven for the first time, we recommend you run it at 450° F on TOAST for approximately 15 minutes to eliminate any factory residue that may remain. This may result in minimal smell and smoke.

Note: The timer on this oven can be set from 0-60 minutes when turned clockwise, or to STAY ON when turned counter-clockwise. When STAY ON is used, the timer must be turned OFF manually.

KEEP WARM:

Keeps cooked food warm. **30 minutes is the recommended maximum warming time. Longer periods of time may over-cook and dry out food.**

1. Turn the function control to KEEP WARM.
2. Turn the timer to the desired time and set the temperature to 150°F.
3. Place food to be warmed on the rack or bake tray in a middle position.
4. When the set time has elapsed, the oven will turn off. Unplug the oven when finished cooking.

HOW TO OPERATE

BROIL:

Upper element heating for fish, steak, browning an open-face sandwich or melting cheese on anything! **We recommend leaving the oven door slightly ajar when broiling.**

1. Turn the function control to BROIL.
2. Preheat the oven at the desired temperature, per your recipe, for 5-10 minutes.
3. Place food on the wire rack and brush with sauces or oil, as desired.
4. When preheating is done, place the wire rack on the bake tray/drip pan and slide into a middle position.
5. Turn the timer to the desired time or to STAY ON.
6. If needed, turn food over midway through the cooking time.
7. When broiling is completed, turn the timer control to OFF. Unplug the oven when finished cooking.

BROILING GUIDE:

*Cooking results may vary. Adjust these times to your individual requirements. **Use of a meat thermometer is recommended.***

MEAT	OVEN TEMPERATURE	TOTAL COOKING TIME
Rib Steak	450°F	20-30 mins.
T-Bone Steak	450°F	20-30 mins.
Hamburger	450°F	15-20 mins.
Breaded Fish Filet	375°F	20-30 mins.
Salmon Steak (1" thick)	400°F	20-25 mins.

HOW TO OPERATE

ROTISSERIE:

Upper element heating for roasts, chicken, ham, etc. **We recommend a maximum weight of 4 pounds of food on the rotisserie spit.** Food should be bound in cooking twine to help cook evenly, and so the rotisserie rotates smoothly.

1. Turn the function control to ROTISSERIE.
2. Preheat the oven at the desired temperature, per your recipe, for 5-10 minutes.
3. Spear the food onto the rotisserie spit. Secure the forks with screws, centering the food on the spit.
4. When preheating is done, insert the pointed end of the spit into the drive socket on the right side of the oven wall. Make sure that the square end of the spit rests on the support on the left side of the oven wall.
5. Slide the drip pan onto a lower position to catch drippings.
6. Turn the timer to the desired time or STAY ON.
7. When cooking is completed, turn the timer to OFF. Unplug the oven when finished cooking.
8. Remove the food from the oven by placing the hooks of the rotisserie removal tool under the grooves on either side of the spit. Lift the left side up and out. Then pull the spit out of the drive socket on the right.
9. Let the food rest on a platter or cutting board for 5 minutes before carefully removing the spit.

ROTISSERIE GUIDE:

*Cooking results may vary. Adjust these times to your individual requirements. **Use of a meat thermometer is recommended.***

MEAT	OVEN TEMPERATURE	TIME PER POUND
Beef Roast	350°F	30-35 mins.
Pork Roast	350°F	45-50 mins.
Ham	350°F	45-50 mins.
Chicken	450°F	30-40 mins.
Turkey	450°F	30-40 mins.

HOW TO OPERATE

TOAST:

Upper and lower element heating.

1. Turn the function control to TOAST.
2. Set the the temperature to 450°F.
3. Place food to be toasted on the wire rack in a middle position.
4. Turn the timer to the desired time or to STAY ON.
5. When toasting is completed, turn the timer control to OFF. Unplug the oven when finished cooking.

BAKE:

Lower element heating for baking cakes, pies, and cookies, or for roasting poultry, beef, pork, etc.

1. Turn the function control to BAKE.
2. Preheat the oven, per your recipe, at the desired temperature 5-10 minutes.
3. When preheating is done, place food in the pan on the wire rack in a lower or middle position.
4. Turn the timer to the desired time or to STAY ON.
5. When baking is completed, turn the timer control to OFF. Unplug the oven when finished cooking.

CLEANING & CARE

1. Turn off and unplug the toaster oven.
2. Always allow the toaster oven to cool completely before cleaning.
3. **Do not use abrasive brushes or pads, or harsh cleaning solutions.**
4. Use a soft cloth, sponge or rubber spatula to remove any stuck-on food or residue.
5. Wipe the interior walls with a soft cloth, using warm, soapy water.
6. Wipe the exterior with a damp cloth.
7. All accessories should be washed in hot, soapy water, or may be washed in a dishwasher.
8. Do not immerse any electrical appliance, its cord, or its plug, into water.
9. Ensure all parts are dried thoroughly before reassembling and using the toaster oven.

RECIPES

Avocado Toast With Egg

- 1 slice bread
- 1 egg
- ½ avocado

1. Preheat oven to 450° F on TOAST.
2. Spray an oven safe bowl with cooking spray, then add the egg.
3. Place the bowl on the center rack and TOAST at 450° F for 2 minutes.
4. When 2 minutes have passed, add the slice of bread to the center rack next to the bowl.
5. Toast both items for approximately 3 minutes at 450° F or until done.
6. Remove the toast and spread with avocado; top with the egg.
7. Salt and pepper to taste or add a dash of hot sauce.

Serves 1

Bruschetta

- | | |
|---|------------------------------|
| 1 baguette, sliced into ¾" thick pieces | 2 t. minced garlic |
| ¼ c. olive oil | ½ t. salt |
| 1 can (14 oz.) diced tomatoes, drained | ¼ t. black pepper |
| 3 T. fresh basil, chopped | ¼ c. Parmesan cheese, grated |

1. Preheat oven to 350°F on TOAST.
2. Brush the baguette slices with olive oil on one side; place slices with olive oil side-up on an oven safe pan.
3. TOAST until bread is lightly browned on top.
4. Mix the remaining olive oil, tomatoes, basil, garlic, salt and pepper in a bowl.
5. When toast is done, top each slice with tomato mixture and sprinkle with Parmesan. Serve immediately.

Serves 4 as an appetizer

Classic Margherita Pizza

1 T. olive oil
2 cloves roasted garlic, minced
8" - 12" premade pizza crust
¼ c. pizza or tomato sauce
2 plum tomatoes, sliced
handful of fresh basil leaves
8 oz. *fresh* mozzarella cheese
fresh ground pepper

1. Preheat oven to 450°F on BAKE.
2. Mix the olive oil and garlic together. Spread on top of crust.
3. Top with sauce and tomatoes.
4. Thinly slice the basil leaves and sprinkle *half* on top of the tomatoes.
5. Slice the mozzarella into 1/4" - 1/2" pieces. Add to top of pizza.
6. Bake for 14-16 minutes on middle rack, or until the crust is lightly browned and the cheese is bubbly.
7. Remove from the oven and top with remaining basil and pepper to taste.

Serves 4-6

Toaster Oven Meatloaf

1 lb. lean ground beef
1 stalk celery, finely chopped
1 small onion, finely chopped
1 slice of bread, cubed
2 eggs
2 cloves of garlic, minced
salt & pepper
ketchup

1. Preheat oven to 400° F on BAKE.
2. Mix all ingredients except ketchup in a medium bowl (use your hands to mix well).
3. Form the mix into a loaf shape in an oven safe pan (if loaf is more than 2½" thick, add more time).
4. Drizzle ketchup over the top of the loaf, to taste.
5. Bake on middle rack at 400° F for approximately 30 minutes or until center of meatloaf reaches 160° F.

Serves 4

Spice Rubs:

Spice rubs are an excellent way to add flavor and seal in juices while using a rotisserie spit.

1. Center the meat on the rotisserie spit and lock in place.
2. Mix all ingredients together and pat generously on the meat.
3. Follow the *Rotisserie Guide on page 8* for times and temperatures for your cut of meat.
4. When done, carefully remove the meat from the spit, and let it rest at least 5 minutes before serving.

Chicken or Pork Loin Rub Ingredients:

2 T. kosher salt	1½ t. dried rosemary
2 T. brown sugar	1½ t. dry mustard
1 T. onion powder	1½ t.. ground cumin
1 T. garlic powder	1½ t. dried thyme
1 T. smoked paprika	1½ t. cayenne pepper
1½ t. black pepper	

Beef or Venison Tenderloin Rub Ingredients:

3 cloves fresh garlic, pressed	2 T. kosher salt
1 T. ground black pepper	1 T. ground coriander
1 T. smoked paprika	1 T. onion powder

Quick Lemon Cookies

- 1 package lemon cake mix
- 2 eggs
- ⅓ c. vegetable oil
- 1 t. lemon extract
- ⅓ c. powdered sugar

1. Preheat oven to 375°F on BAKE.
2. Pour cake mix into a large bowl.
3. Stir in eggs, oil, and lemon extract until well blended.
4. Roll dough into a ball (about 1 T. at a time). Drop dough ball into a bowl of powdered sugar. Roll around until lightly covered.
5. Place dough ball on an ungreased cookie sheet.
6. Bake on middle rack for 6 to 9 minutes. The bottoms will be light brown, and the inside chewy.

Makes 12-16 cookies

WARRANTY

Ginny's warrants this product free from defects in material and workmanship for one year from provable date of purchase.

Within this warranty period, Ginny's will repair or replace, at its option, defective parts at no charge, provided the product is returned, freight prepaid with proof of purchase to Ginny's. Allow 2-4 weeks for return shipping.

This warranty does not cover improper installation, misuse, abuse or neglect on part of the owner. Warranty is also invalid in any case that the product is taken apart or serviced by an unauthorized service station.

This warranty gives you specific legal rights and they may vary from state to state.

THE FOREGOING WARRANTIES ARE IN LIEU OF ALL OTHER WARRANTIES AND CONDITIONS, EXPRESS OR IMPLIED, INCLUDING BUT NOT LIMITED TO THOSE OF MERCHANTABILITY OR FITNESS FOR A PARTICULAR PURPOSE.



Ginny's, Inc.
1112 7th Avenue
Monroe, WI 53566

Customer Service: 800-544-1590
8:00 a.m. to Midnight CST, Monday through Friday